

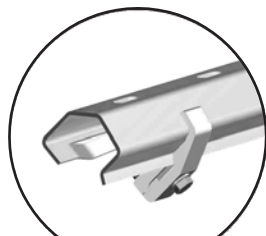

# KIT 5010

**For manuelle Fermatic-systemer:  
For manual Fermatic systems:  
3430 / 3530 / 7530**



3430

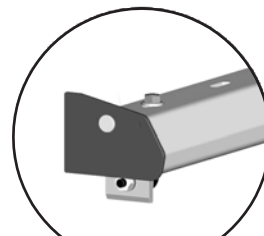

3530 / 7530

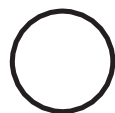

<b>1 - Forholdsregler ved montering / <i>Mounting precautions</i></b> .....	s.2
<b>2 - Transport</b> .....	s.2
<b>3 - Oppbevaring / <i>Storage</i></b> .....	s.2
<b>4 - Produktets karakteristikk / <i>Characteristics</i></b> .....	s.3



<b>5 - Mekanisk montering / <i>Mechanical mounting</i></b> .....	s.6
5.1 - Remstrammer / <i>Belt adjuster</i> .....	s.8
5.2 - Drivenhet til dør / <i>Door driving assembly</i> .....	s.9
5.3 - Motor / <i>Motor</i> .....	s.11
5.4 - Drivrem / <i>Belt</i> .....	s.20
5.5 - Festing av sikkerhetsetiketter / <i>security stickers fixing</i> .....	s.22

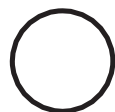

<b>6 - Bruk / <i>Using</i></b> .....	s.22
6.1 - Normal bruk / <i>Normal using</i> .....	s.22
6.2 - Risikoer som følge av handlinger ... / <i>Risks following intentional acts</i> .....	s.22
6.3 - Identifikasjonsetiketter / <i>Identification stickers</i> .....	s.23
6.4 - Rengjøring / <i>Cleaning</i> .....	s.23



<b>7 - Vedlikehold</b> .....	s.24
<b>8 - Kassering / <i>Scrapping</i></b> .....	s.24

Denne anvisningen inneholder instruksjoner om installasjon, bruk og vedlikehold. Vi anbefaler at du leser den nøye og stiller den til brukerens disposisjon.

*This instructions manual includes the mounting, utilization and the maintenance instructions. We recommend to read this carefully and to place it at the user's disposal. The English version of our general conditions of sales and mounting instructions are not binding, and are only given for information purposes. Only the French version can be used in case of legal action.*

# 1 - FORHOLDSREGLER VED MONTERING / MOUNTING PRECAUTIONS

Vennligst overhold gjeldende regler i installasjonslandet.

## **Følgende punkter må sjekkes:**

- Sjekk omgivelsenes klimaforhold. Det kreves en spesialboks for temperaturer under -10 °C.
- Sjekk kompatibiliteten mellom det automatiske settet som skal installeres og det manuelle systemet som brukes.
- Festene til dørens drivenhet må holde høy kvalitet, være laget av et egnet materiale, ha egnet motstandsevne og være fri for enhver opplagt feil i hele deres antatte levetid.

Vennligst følg alle instruksjonene i anvisningen.

*Please respect the regulations that apply in the country of installation.*

- *Check the temperature of the environment. For temperatures lower than -10°C, a low temperature command box is required.*
- *Check the compatibility between the Automatic Kit to be installed with the Fermatic Manual System.*
- *The door drive sub-assembly fixations must be well made and made of suitable material, having an appropriate resistance and be exempt from any obvious fault for their intended working life.*

*Please refer to our mounting instructions.*

# 2 - TRANSPORT

Dette materialet må transporteres beskyttet mot dårlige værforhold.  
Originalemballasjen egner seg for alle typer transport.

Det emballerte settet tåler å stables med 4 andre automatiske sett.

Ansvarer til FERMOD tar slutt:

- så snart kunden eller installatøren åpner esken eller en del av esken,
- så snart esken har blitt utsatt for et slag eller støt slik at den ble revet i stykker.

*This equipment must be protected from bad weather during transport.*

*The original packing is designed for all types of transportation means.*

*The packed kit withstands stacking of 4 others automatic kits.*

*The liability of FERMOD ceases:*

- *as soon as the customer or installer opens the package or a part of the packaging,*
- *as soon as the package has suffered a considerable impact in such a way that it's damaged.*

# 3 - OPPBEVARING / STORAGE

Dette materialet må lagres beskyttet mot dårlige værforhold.

Det emballerte settet tåler å stables med 4 andre automatiske sett.

*This equipment must be protected from bad weather during storage.*

*The packed kit withstands stacking of 4 others automatic kits.*

## 4 - PRODUKTETS KARAKTERISTIKKER / CHARACTERISTICS

Det elektroniske automatiske settet 5010 er utformet for å motorisere følgende manuelle Fermatic-systemer:

*The automatic electronic kit 5010 is designed to motorize the Fermatic manual systems:*

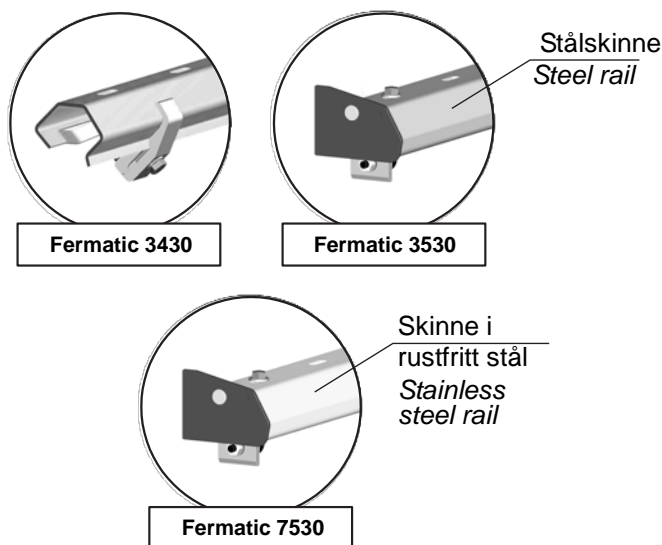

	3430	3530 7530
<b>Maks dørvekt</b> <i>Maxi door weight</i>	150 Kg	200 Kg
<b>Motoreffekt</b> <i>Motor power</i>	370W	
<b>Motorens beskyttelsesgrad</b> <i>Protection of the motor</i>	IP 55	
<b>Brukstemperatur</b> <i>Using temperature</i>	-30 °C → +45 °C *	

\* For negative temperaturer:

se ekstrautstyr for lav temperatur - separat anvisning

\* For negative temperature:

see «option for minus temperature» – Separate mounting instructions

**i** Fermatic-systemer 2120/2130/2150 - 2320 - 2420: se separat anvisning for NMKit5010\_RailAlu  
 Fermatic systems 2120/2130/2150 - 2320 - 2420: see separate mounting instructions MKit5010\_RailAlu

Disse manuelle systemene er brukt for vannrette skyvedører med bestemte karakteristikk (isotermisk, akustisk, renrom, støvtett ...).

Systemet har en integrert lås (som ikke erstatter bruken av en mekanisk lås) og kan utstyres med en vannrett eller loddrett sikkerhet (avhengig av gjeldende regler i installasjonslandet).

*These manual systems are used for horizontal sliding doors with defined characteristics (iso-thermal, acoustical, clean room, dust-tight...).*

*It has an integrated lock (which does not replace the use of a mechanical lock), and can be equipped with horizontal or vertical safety device (according to the regulations that apply in the country of installation).*

### ■ Spesifikt ekstrautstyr / Options

Utstyret nedenfor kan fås for Fermatic-systemene utstyrt med Kit 5010:

Vannrett eller loddrett sikkerhet (avhengig av gjeldende regler i installasjonslandet)

Blinkende lys

Kontakt oss for alle spesielle forespørsler (motstandsdyktig kant, trekksnor ...).

#### Håndtak:

Alle håndtakene for de manuelle Fermatic-systemene passer for systemer utstyrt med Kit 5010.

#### Options:

Horizontal or vertical safety device (according to the regulations that apply in the country of installation)

Flashing light

Please contact us for other options (resistive edgemount, pull cord...).

#### Handles:

Every handle for Fermatic manual systems fit on systems equipped with kit 5010.

## Deleliste / Parts list

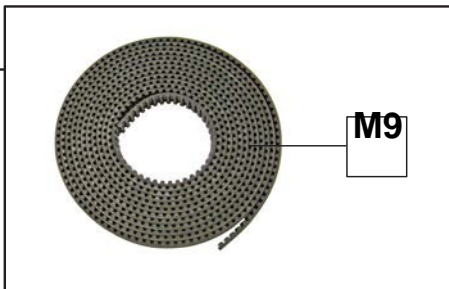
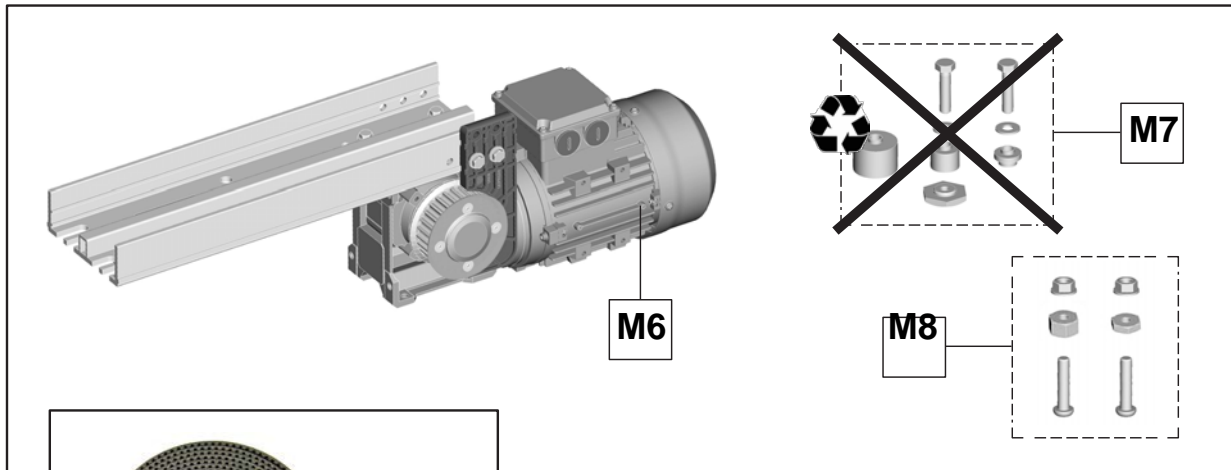
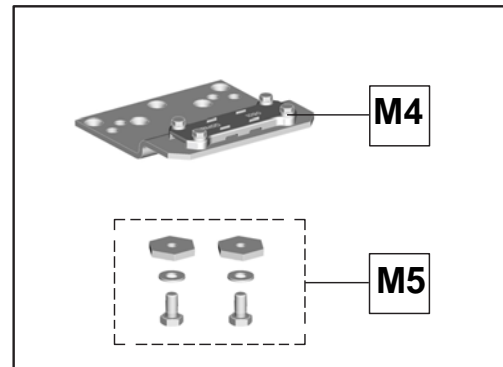
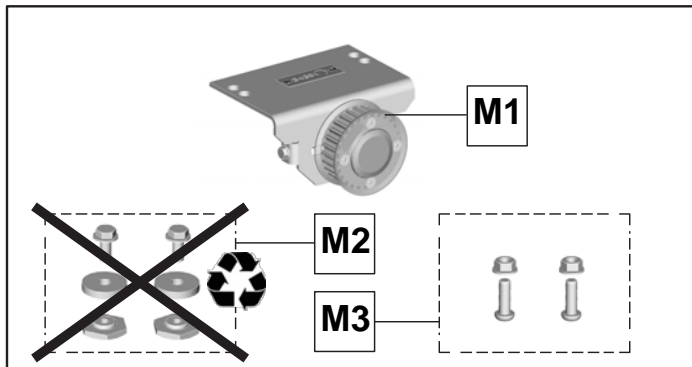

<b>M1</b>	Remstrammer <i>Belt adjuster</i>
<b>M3</b>	Skruer til strammeren / <i>Adjuster screws</i>
<b>M4</b>	Drivenhet til dør <i>Door driving assembly</i>
<b>M5</b>	Skruer til drivenhet <i>Door driving assembly screws</i> 3430 - 3530 - 7530
<b>M6</b>	Motorenhet <i>Motor unit</i>
<b>M8</b>	Skruer til motoren / <i>Motor screws</i> 3430 - 3530 - 7530
<b>M9</b>	Drivrem / <i>Belt</i>

<b>M2</b>	MÅ IKKE BRUKES	
<b>M7</b>	MÅ IKKE BRUKES	

## Verktøy / Tools

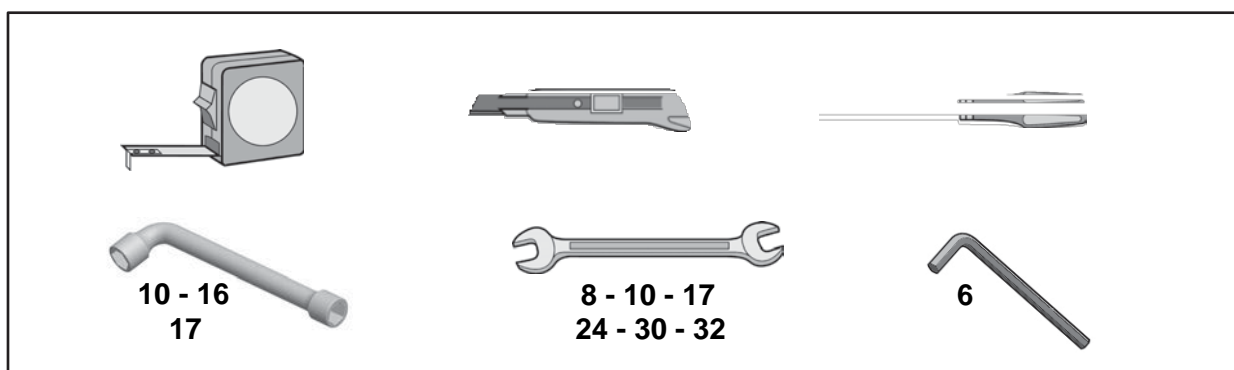

## Mål / Dimensions

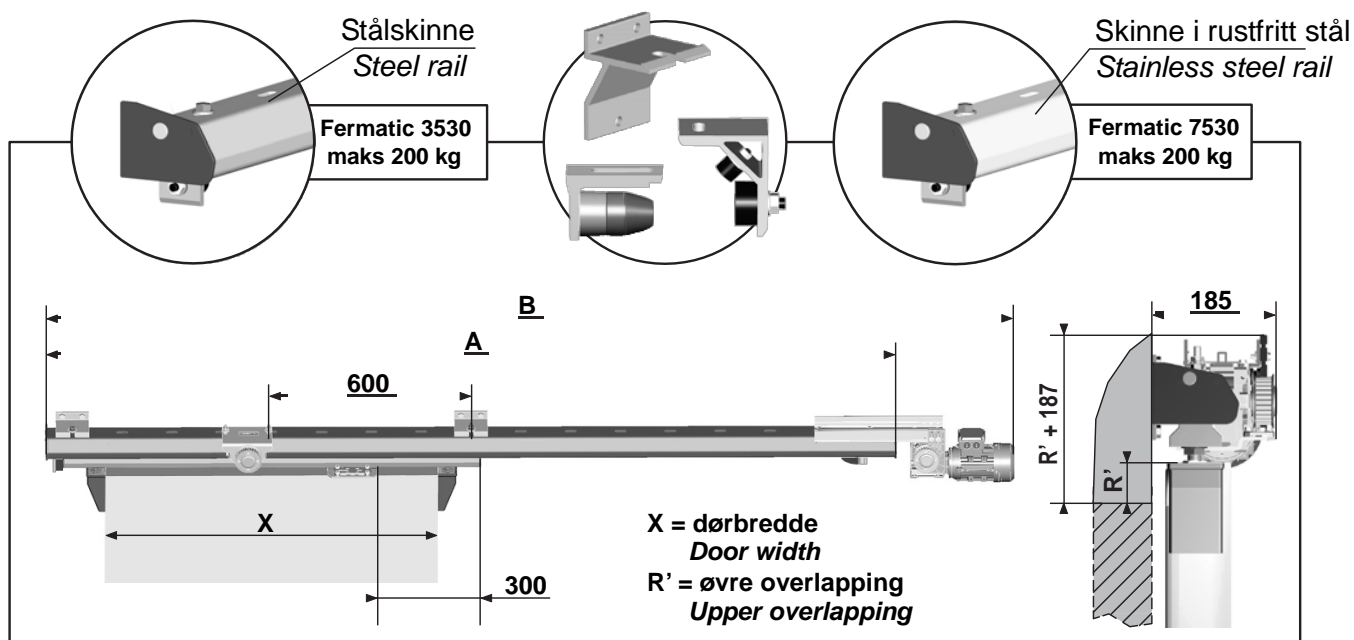
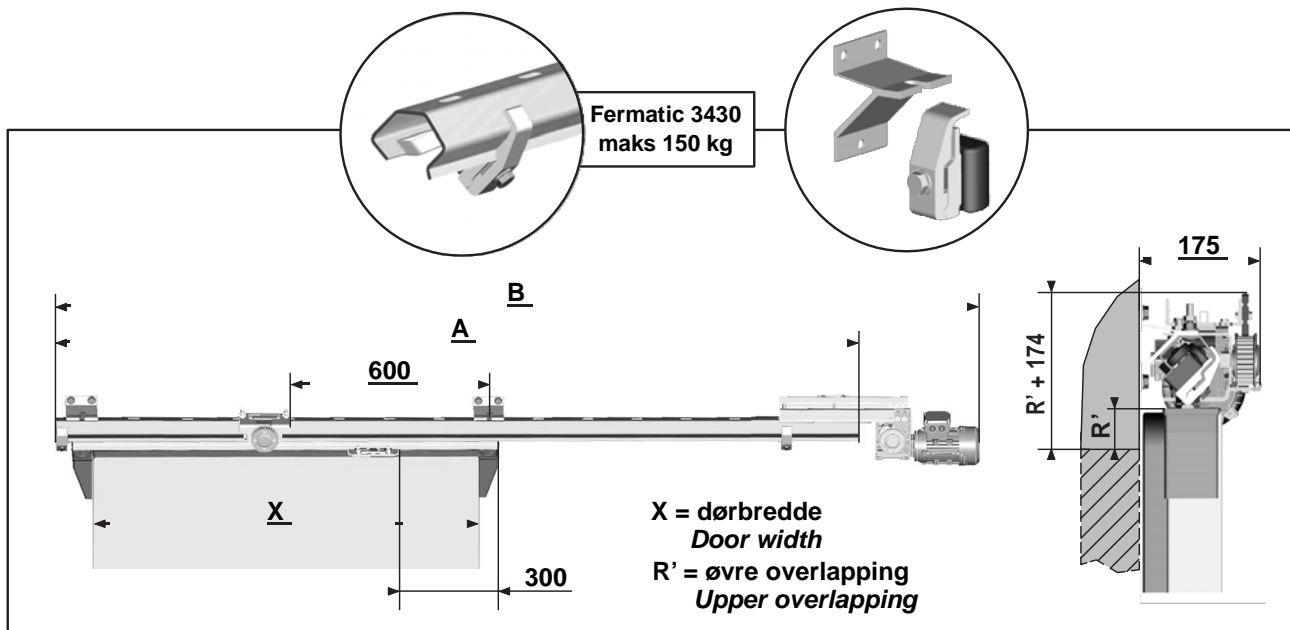

	3431 3531 / 7531	3432 3532 / 7532	3433 3533 / 7533	3434 3534 / 7534	3435 3535 / 7535	3436 3536 / 7536	3537 / 7537	3538 / 7538
<b>X</b>								
<b>min</b>	840	1141	1441	1741	2041	2341	2641	2941
<b>maks</b>	1140	1440	1740	2040	2340	2640	2940	3240
<b>A</b>	2550	3150	3750	4350	4950	5550	6150	6750
<b>B</b>	2910	3510	4110	4710	5310	5910	6510	7110

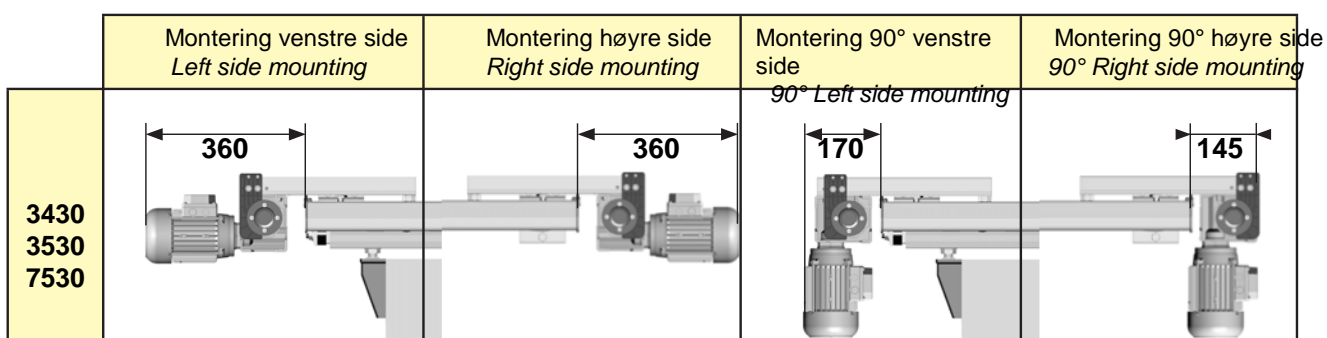

## 5 - MEKANISK MONTERING / MECHANICAL MOUNTING

Monteringen av kit 5010 er den samme uansett hvilken side døren åpnes på. Det anbefales å montere motoren på høyre side av skinnen.

Motoren kan monteres i standard posisjon eller med 90° helling.



*Installation of the Kit 5010 is the same regardless of the opening side of the door. It's recommended to install the motor right side of the rail.*

*Motor can be mounted in standard or 90° direction.*

### MONTERING AV MOTOREN PÅ HØYRE SIDE AV SKINNEN MOTOR MOUNTING RIGHT SIDE OF THE RAIL

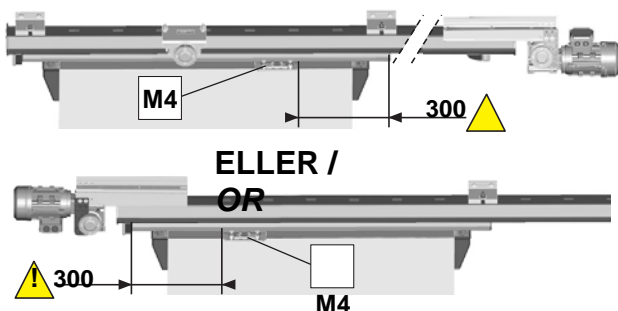
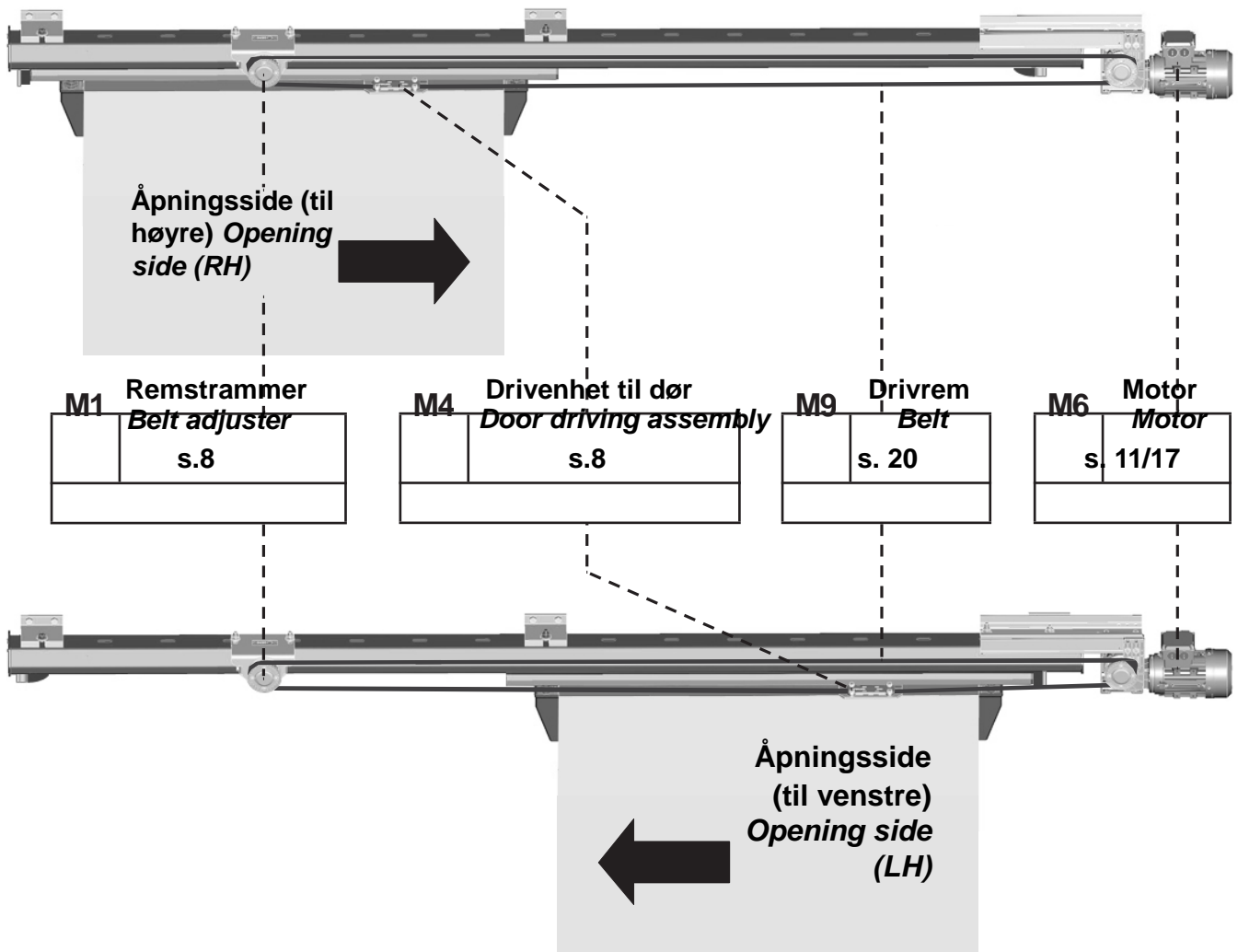

Posisjonen til dørens drivenhet (M4) er forskjellig avhengig av motorens monteringside på skinnen (høyre eller venstre side: se neste side).

*The position of the door driving assembly (M4) is different according to the mounting side of the motor onto the rail (left or right side: see next page).*

## MONTERING AV MOTOREN PÅ VENSTRE SIDE AV SKINNEN MOTOR MOUNTING LEFT SIDE OF THE RAIL

Hvis det ikke er mulig å montere motoren på standard vis (høyre side av skinnen), er det fullt mulig å montere den på venstre side, med noen små endringer i forhold til standard montering:

- ☑ Snu stillingen til remstrammeren (**M1**) og justeringskruen (**A**)
- ☑ Snu stillingen til dørens drivenhet (**M4**)
- ☑ Snu stillingen til motoren (**M6**) på motorbraketten

Når de ulike delene av settet monteres, følg instruksjonene for standard montering nedenfor, **men gå motsatt vei**.

*Depending on the system installation, the space available in the right end rail can be short for mounting the motor in its standard configuration (right side of the rail). In that event it's possible to mount the motor left side of the rail, with very little changes compared with standard mounting. It's necessary to:*

- ☑ Reverse the position of the belt adjuster (**M1**) and its adjustment screw (**A**)
- ☑ Reverse the position of the door driving assembly (**M4**)
- ☑ Reverse the position of the motor (**M6**) on its bracket

*To mount the different parts of the Kit, see the drawings below.*

**Remember to reverse the drawings** of the standard mounting.

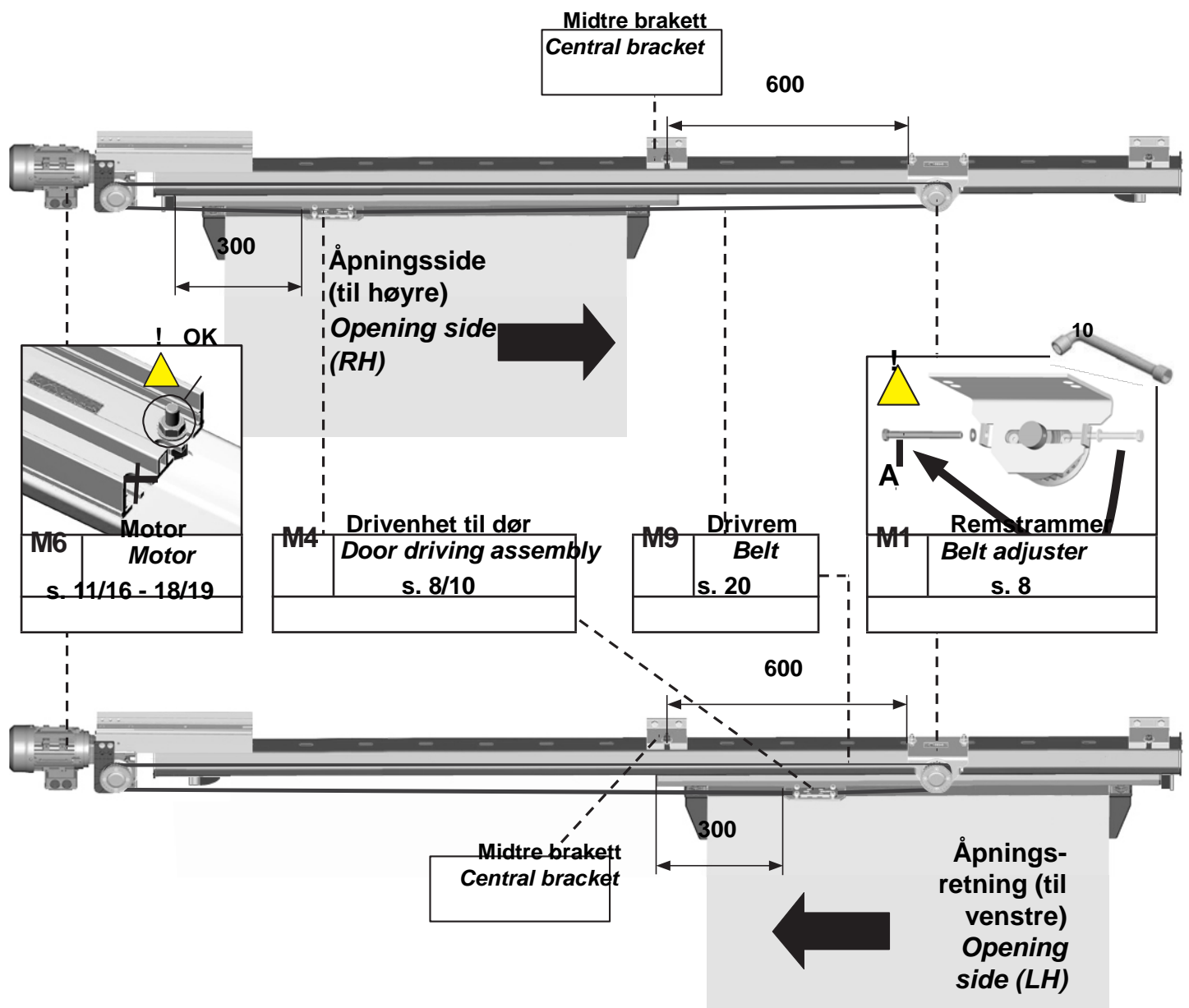

## 5.1 REMSTRAMMER / BELT ADJUSTER

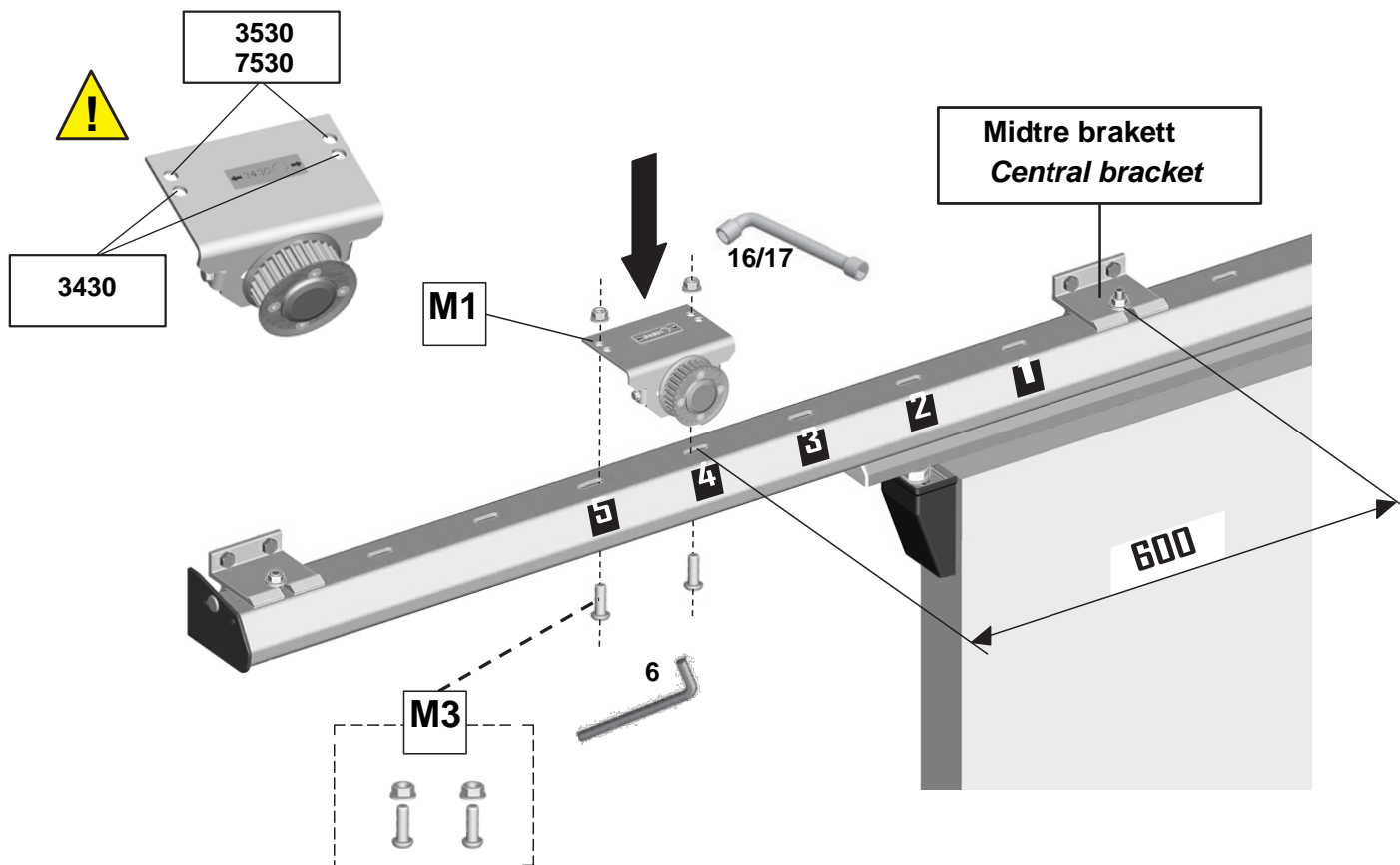

## 5.2 DRIVENHET TIL DØR / DOOR DRIVING ASSEMBLY

i

Monteringen av dørens drivenhet (M4) er den samme på systemene 3430 - 3530 - 7530. Men **posisjonen er forskjellig** avhengig av motorens monteringside på skinnen (høyre eller venstre side).  
*The mounting of the door driving assembly (M4) is the same for 3430 - 3530 - 7530 systems. It's position is different according to the mounting side of the motor onto the rail (left or right side).*

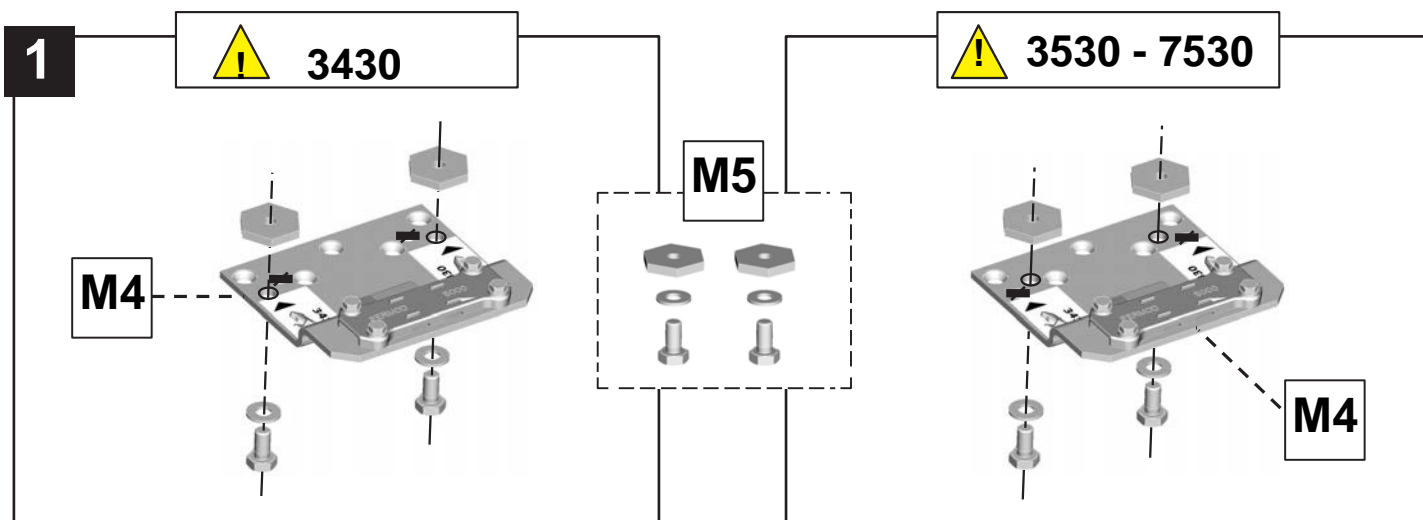



**MED MOTOR PÅ HØYRE SIDE AV SKINNEN**  
**WITH MOTOR RIGHT SIDE OF THE RAIL**

**1\***

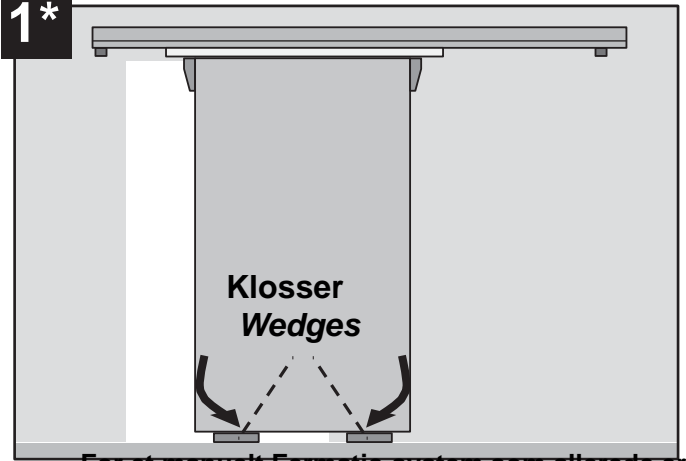
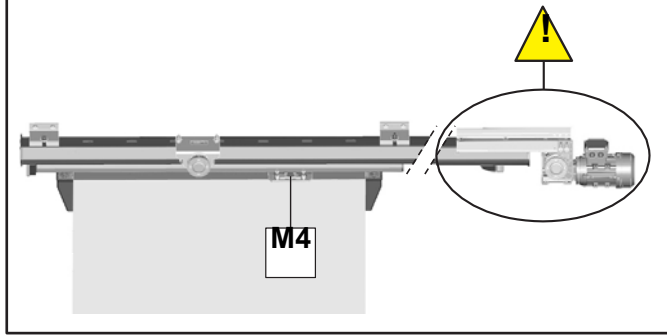

For et manuelt Fermatic-system som allerede er  
 = installert

\* For a manual Fermatic system already installed

**2\***

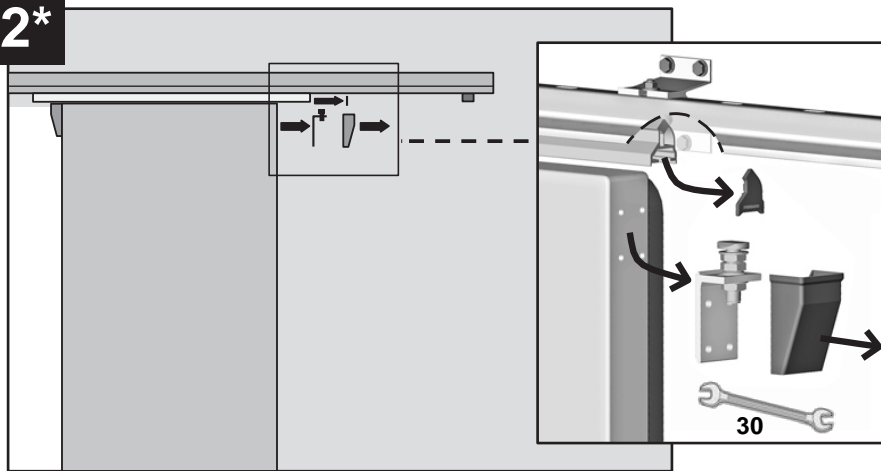

**3**

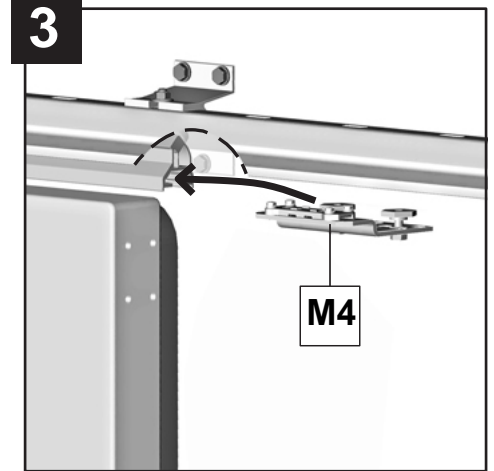

**4**

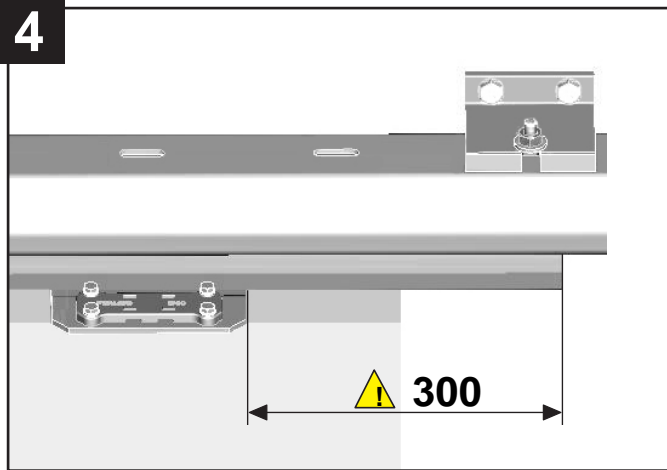

**5**

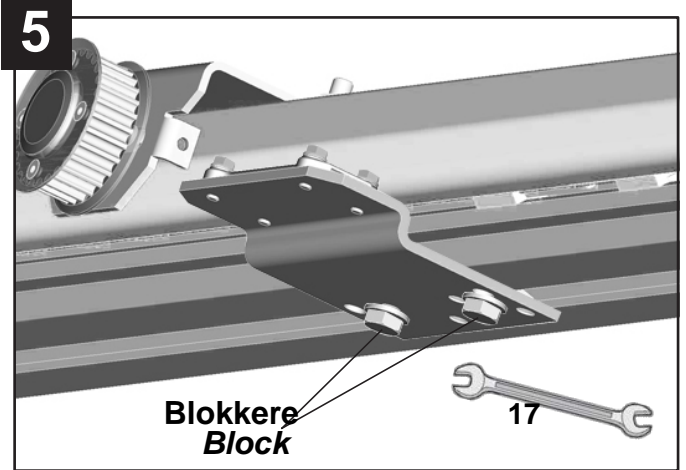

**6\***

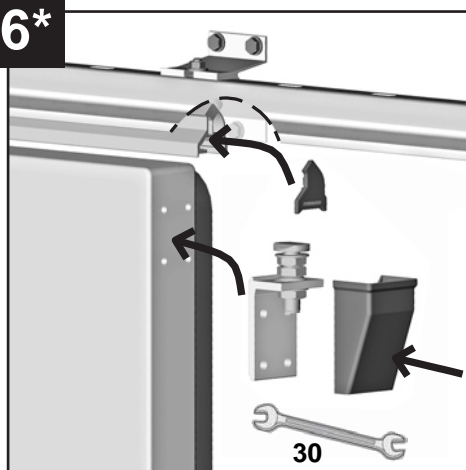

**7\***

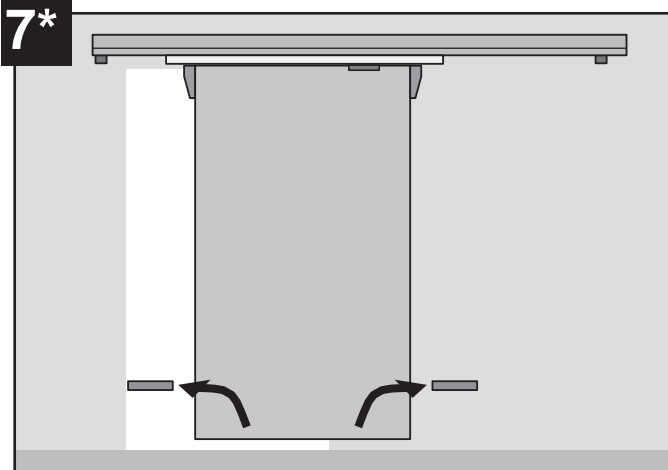

**MED MOTOR PÅ VENSTRE SIDE AV SKINNEN**  
**WITH MOTOR LEFT SIDE OF THE RAIL**

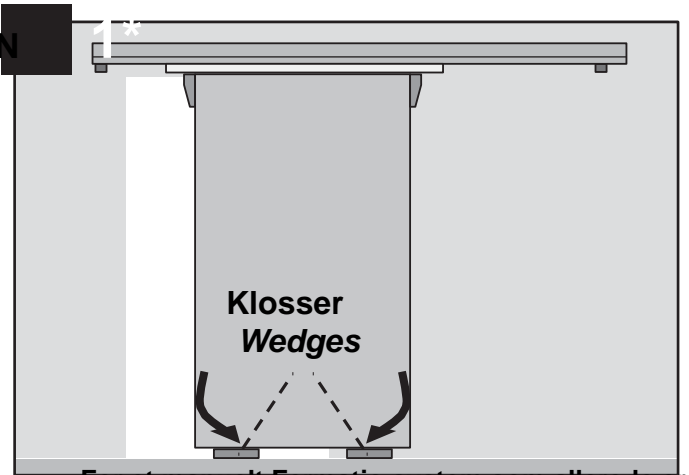
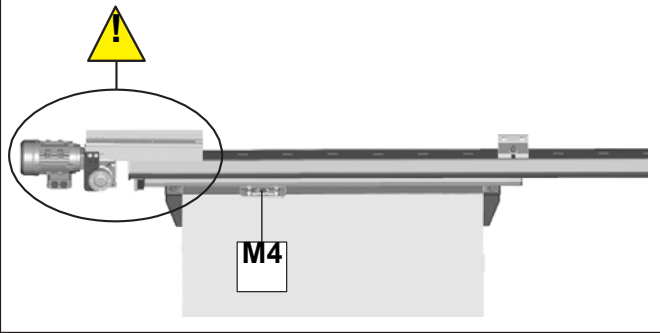

For et manuelt Fermatic-system som allerede er installert = installert



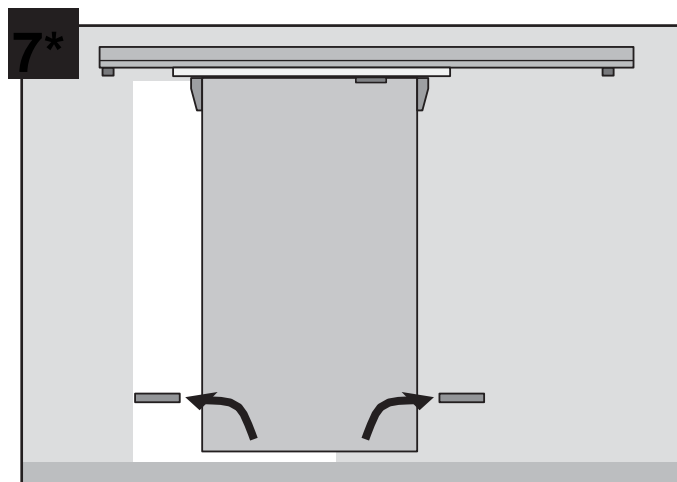
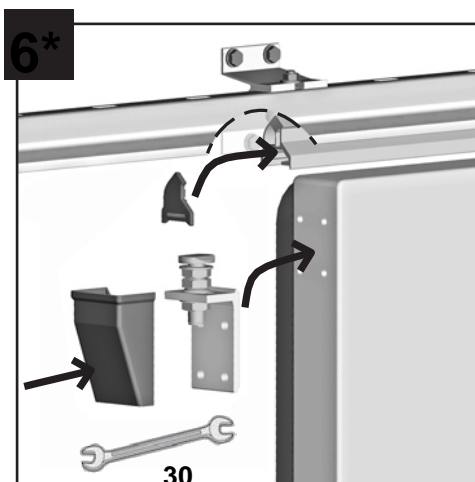
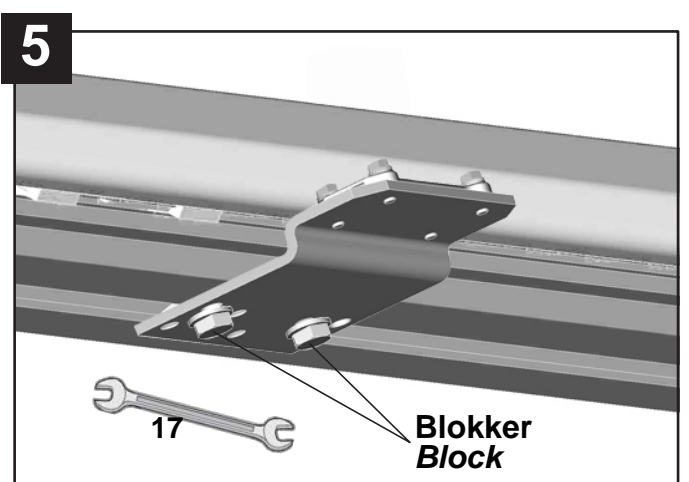
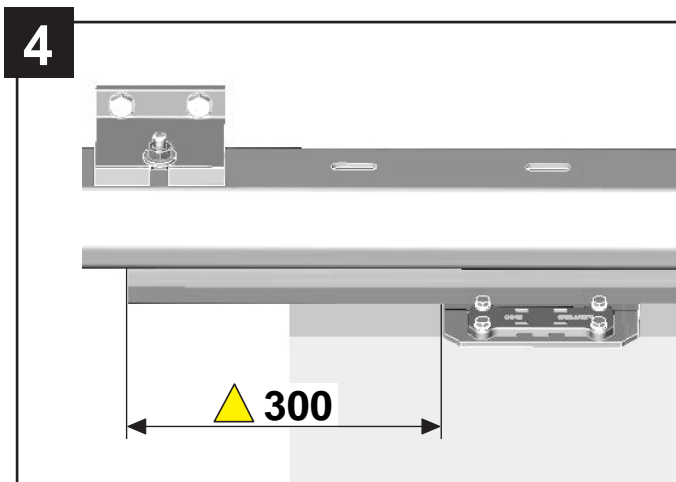
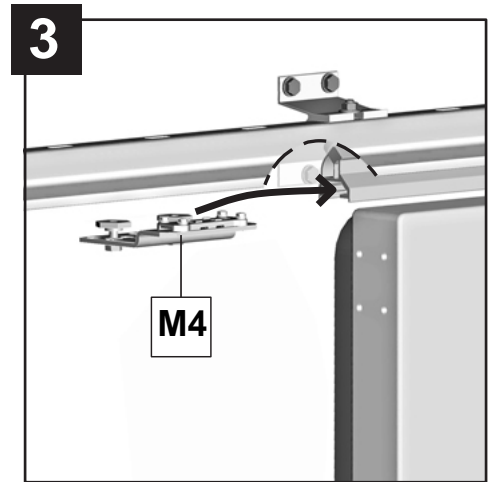
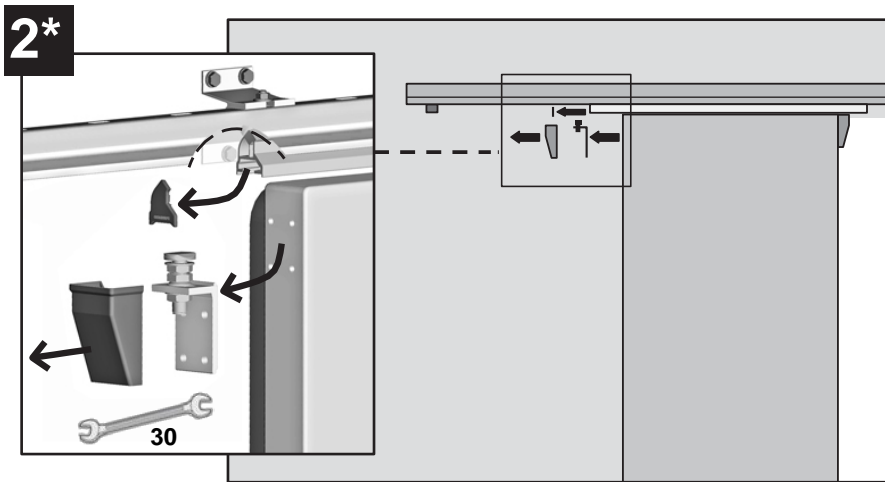

\* For a manual Fermatic system already installed

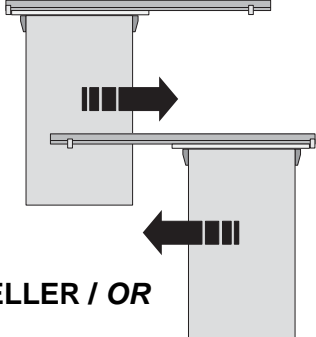
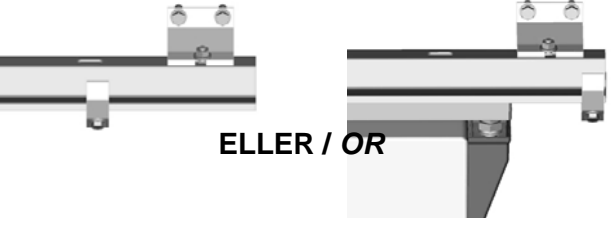
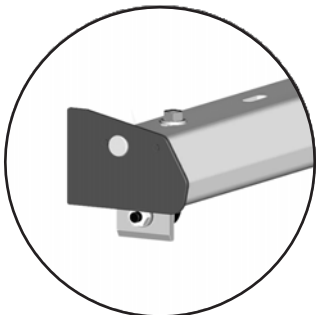
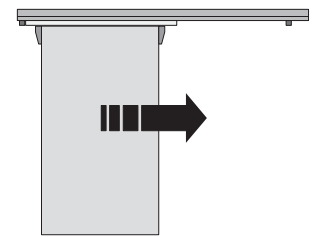
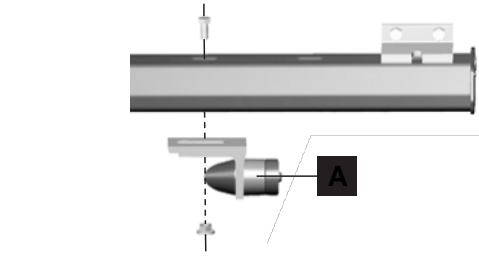
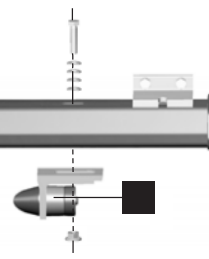

## 5.3 MOTOR / MOTOR

Avhengig av Fermatic-systemet (3430 eller 3530/7530) og typen endestykke på skinnen, finnes det 5 ulike måter å montere motoren på:

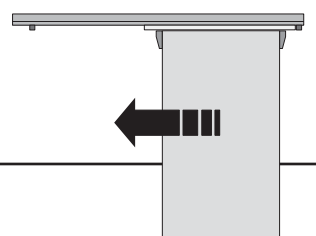
*The motor mounting depends on Manual Fermatic system (3430 or 3530/7530) and butt model mounted onto the rail. There are 5 different ways to mount the motor:*

SYSTEMER SYSTEMS	ÅPNINGSSIDE OPENING SIDE	TILFELLE / CASE	
 <p>3430</p>	 <p>ELLER / OR</p>	<p>Nr. 1 ▼ s.12</p>	 <p>ELLER / OR</p>
 <p>3530 7530</p>		<p>Nr. 2 ▼ s.13</p>	
		<p>Nr. 3 ▼ s.14</p>	 <p>B ELLER / OR</p>
		<p>Nr. 4 ▼ s.15</p>	 <p>E ELLER / OR</p>
		<p>Nr. 5 ▼</p>	

C **ELLER /  
OR** D



F **ELLER /  
OR** G





**Nr. 1 - FERMATIC 3430**

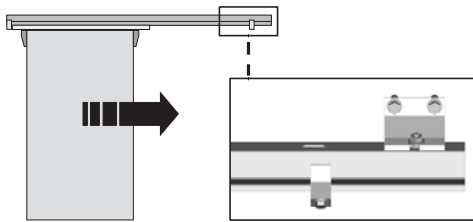
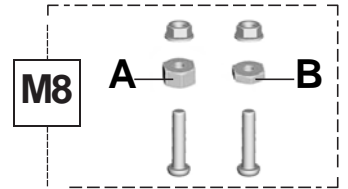

ELLER /  
OR

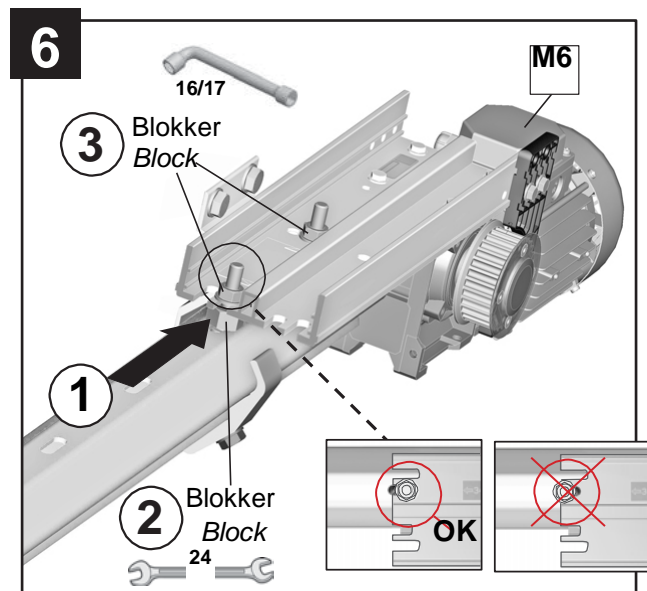
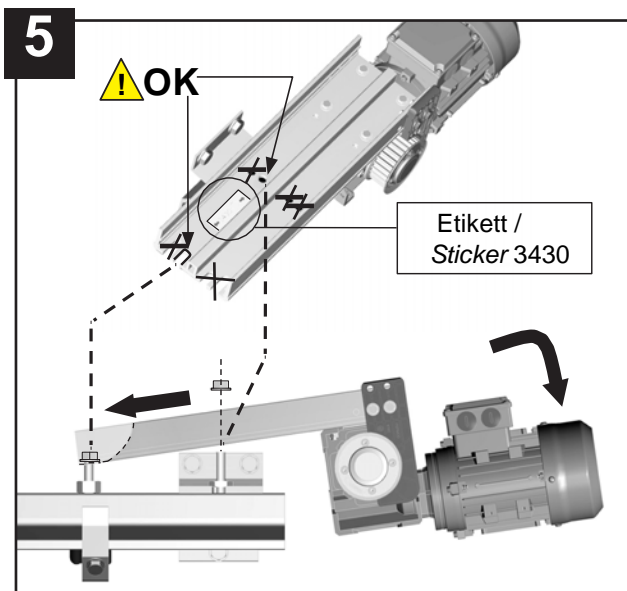
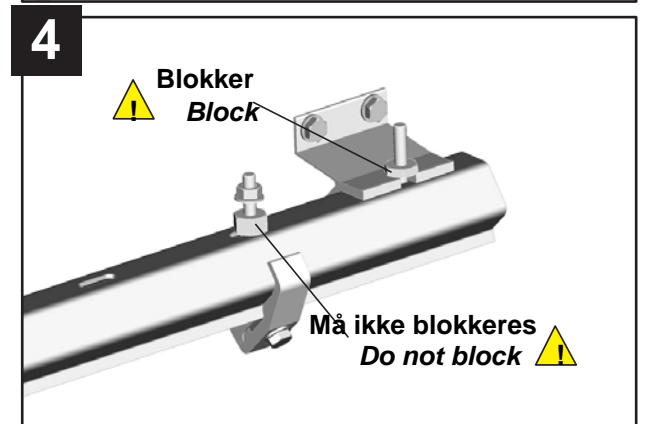
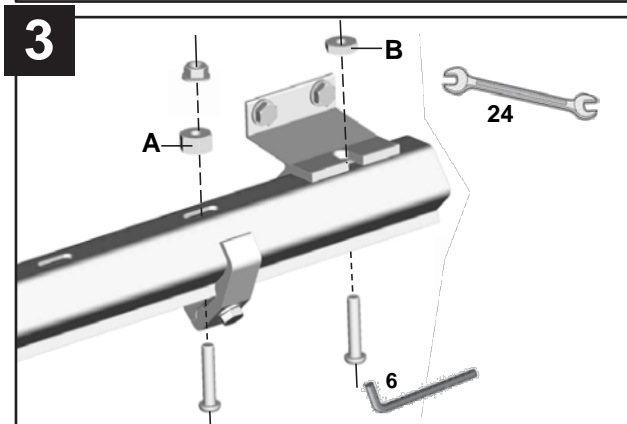
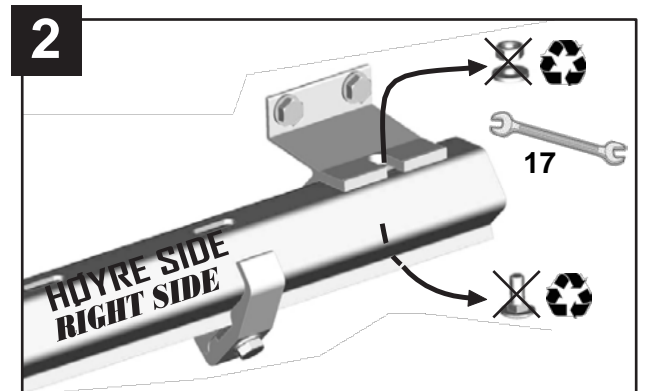
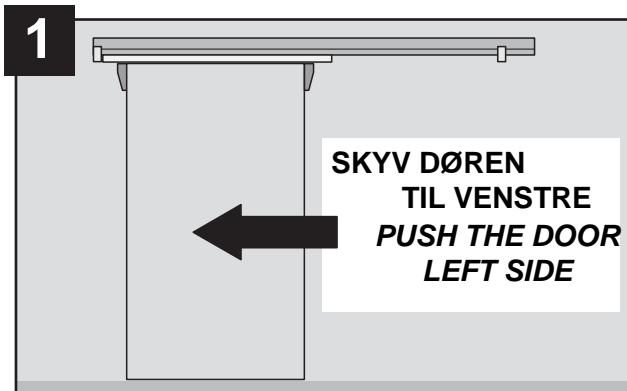
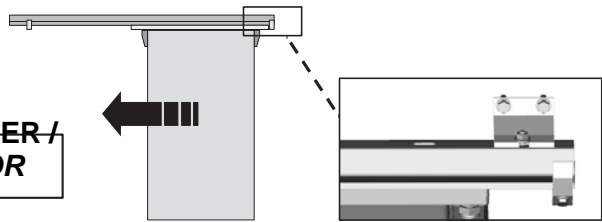

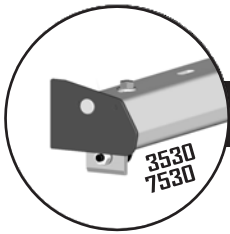

**Nr. 2 - FERMATIC 3530/7530**

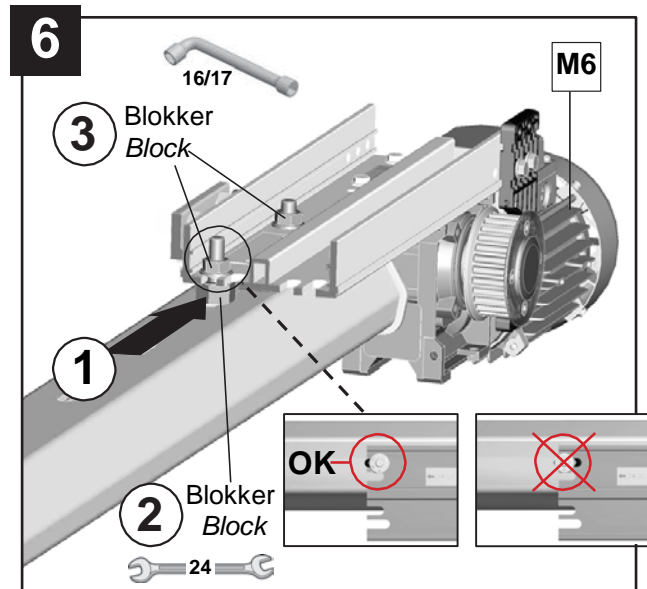
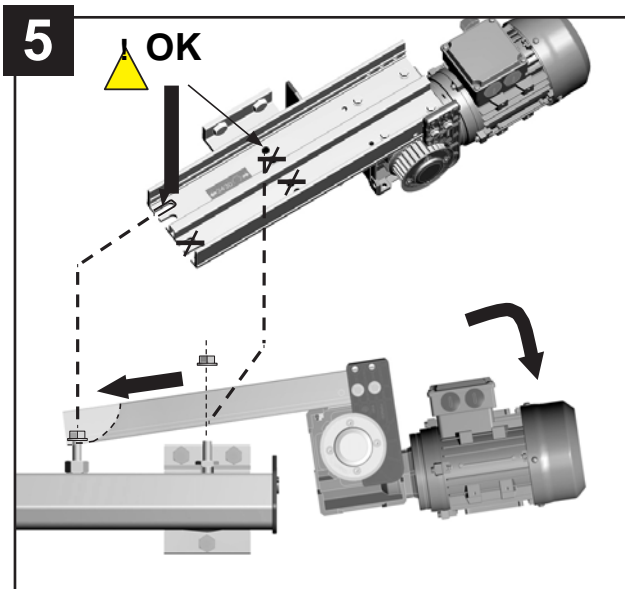
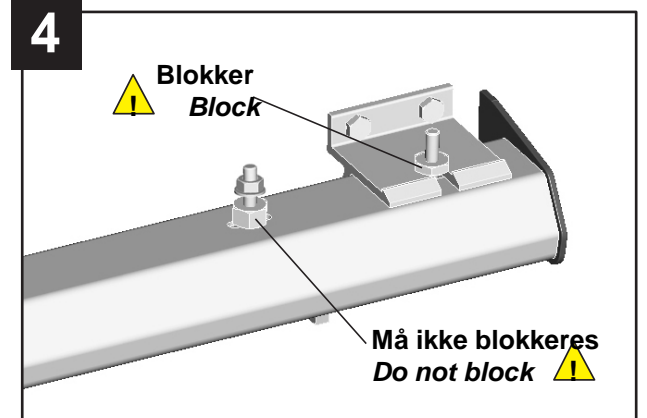
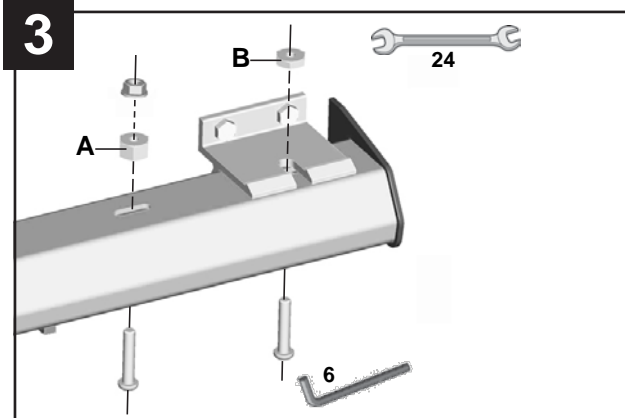
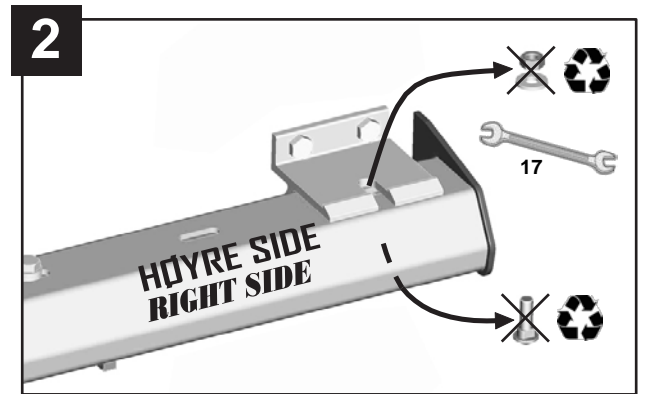
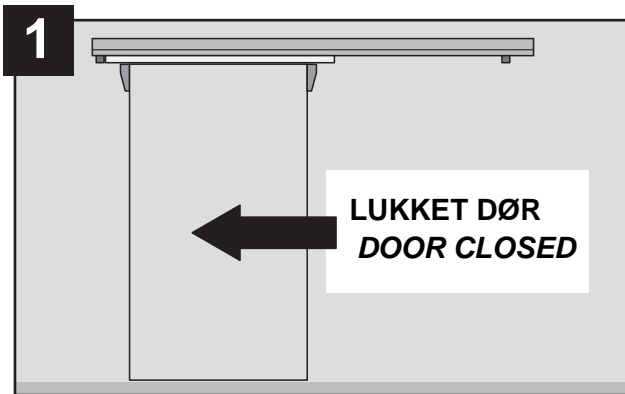
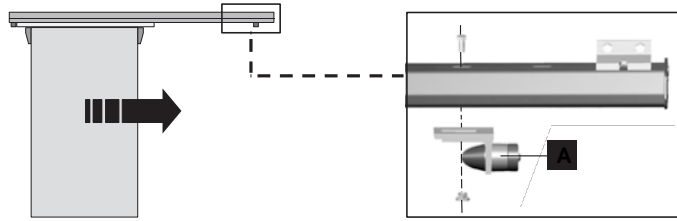
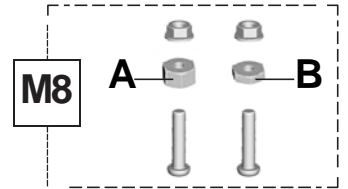

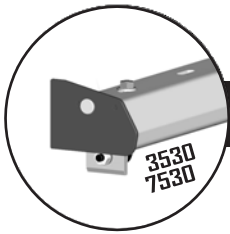

**Nr. 3 - FERMATIC 3530/7530**

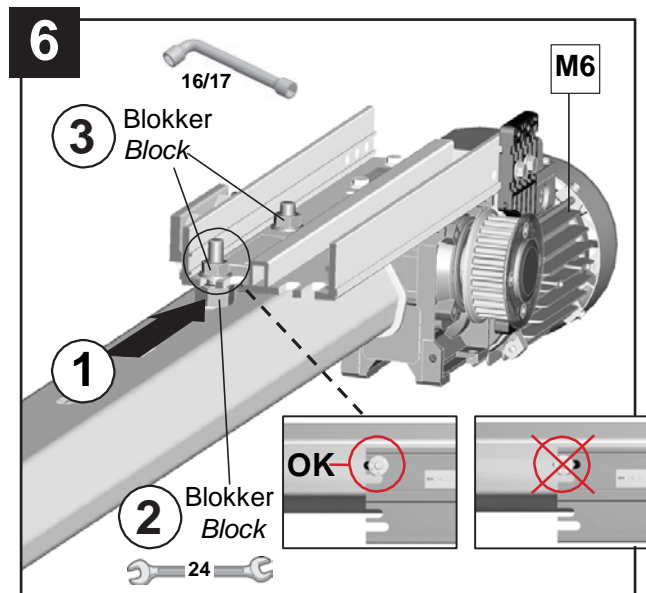
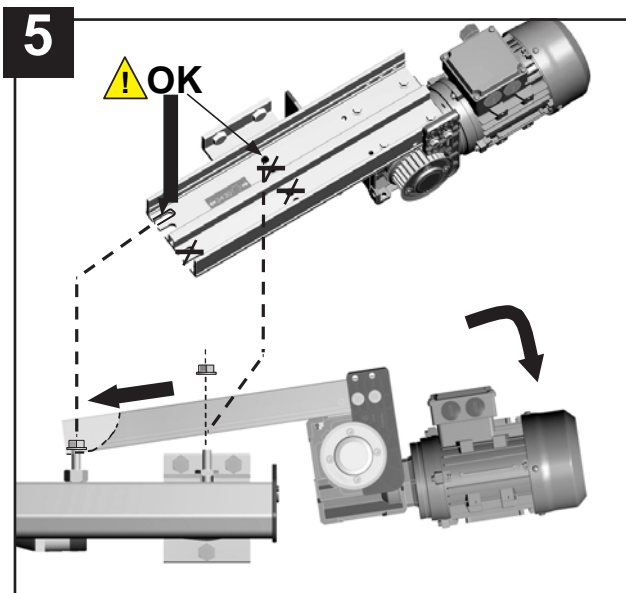
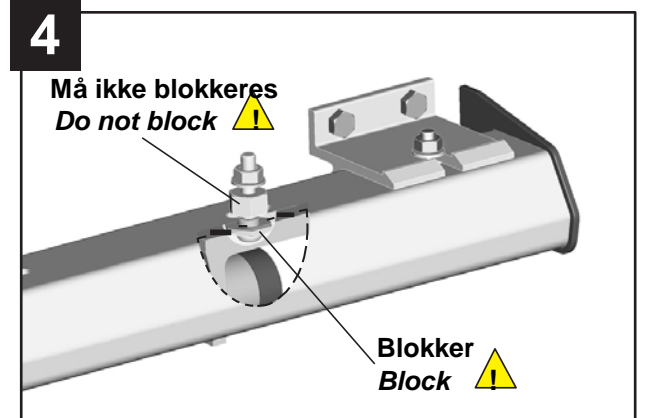
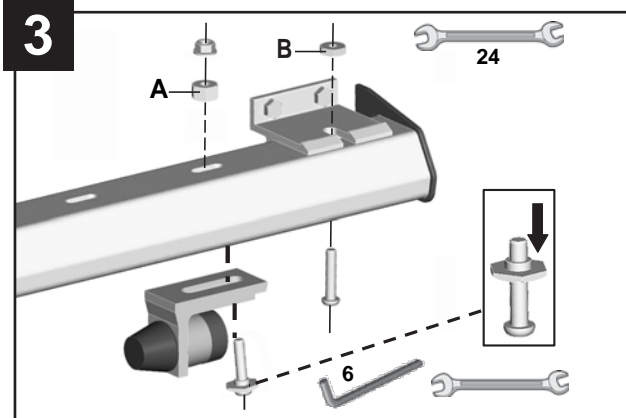
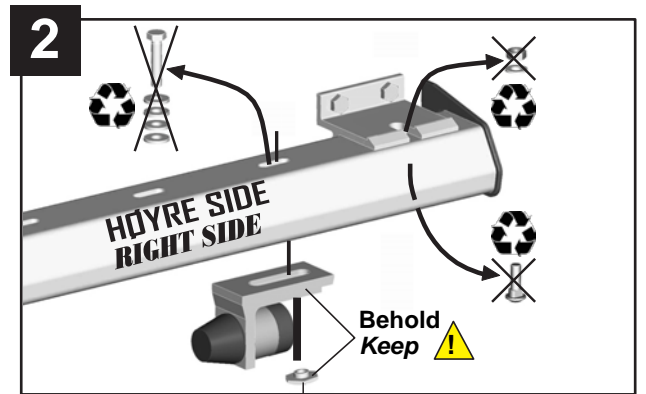
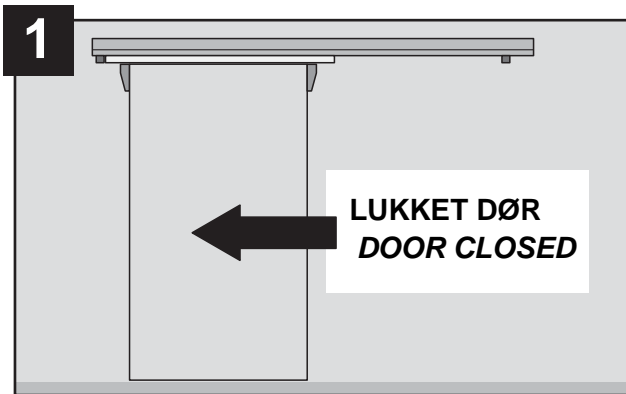
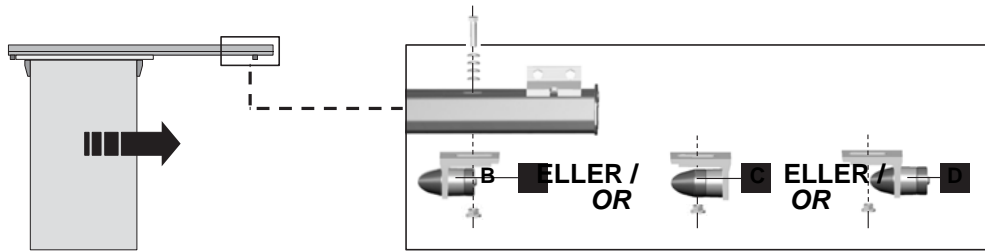
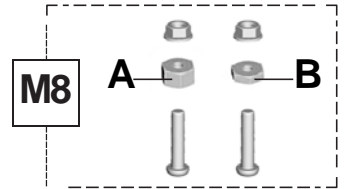

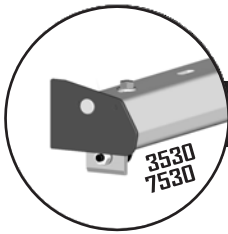

**Nr. 4 - FERMATIC 3530/7530**

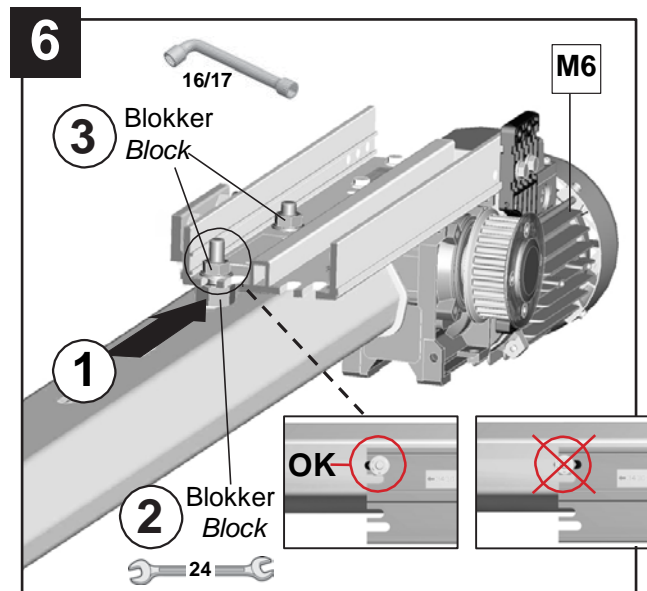
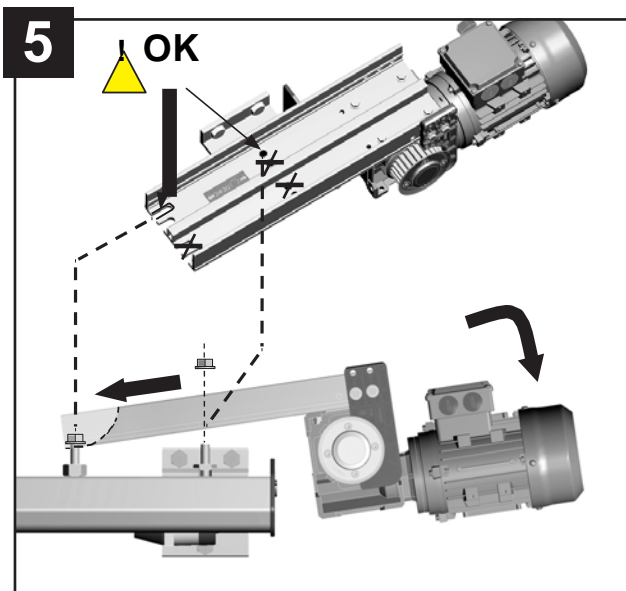
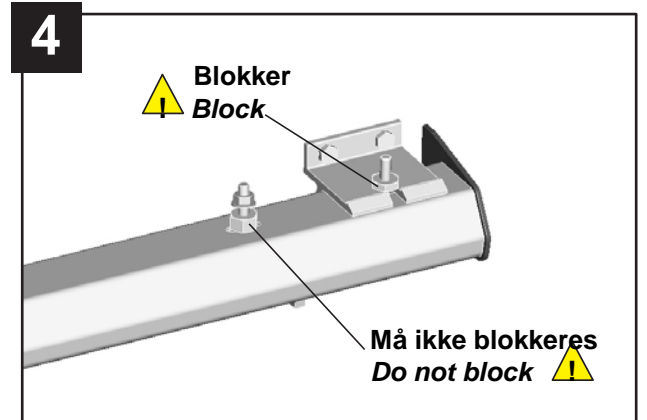
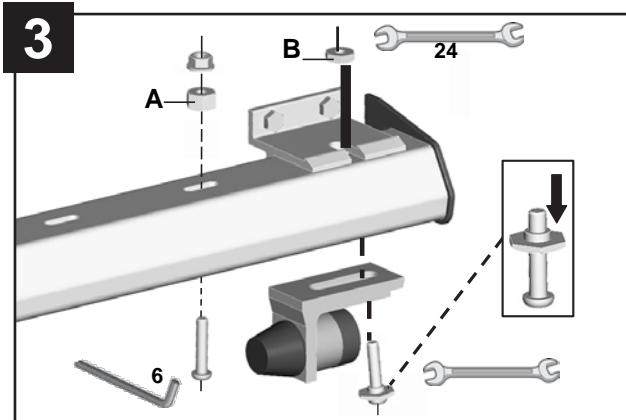
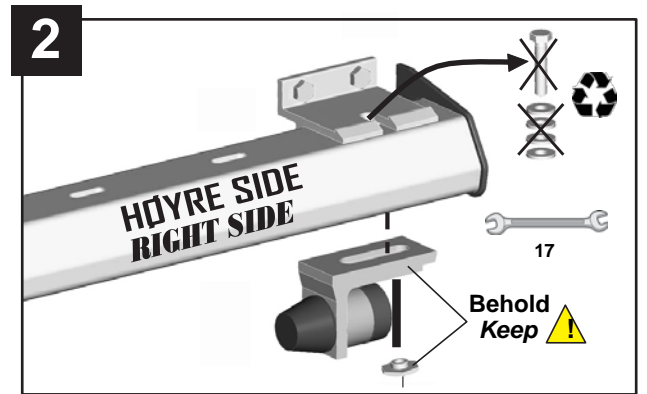
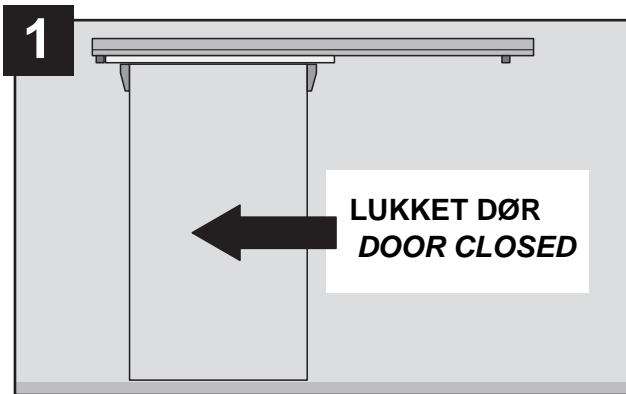
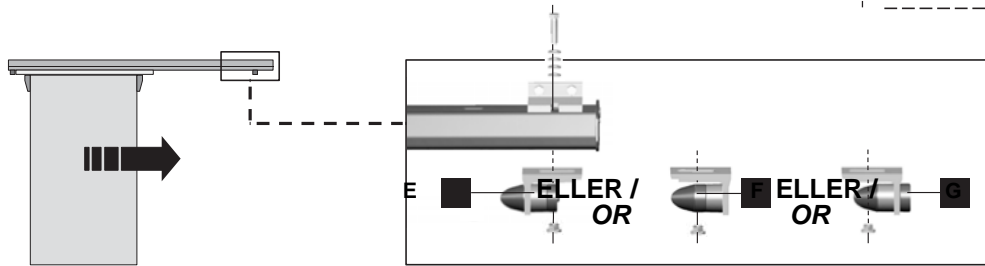
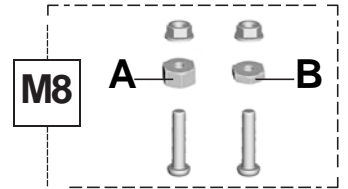



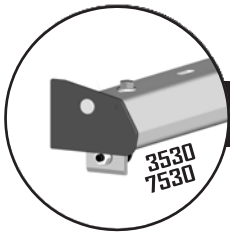

**Nr. 5 - FERMATIC 3530/7530**

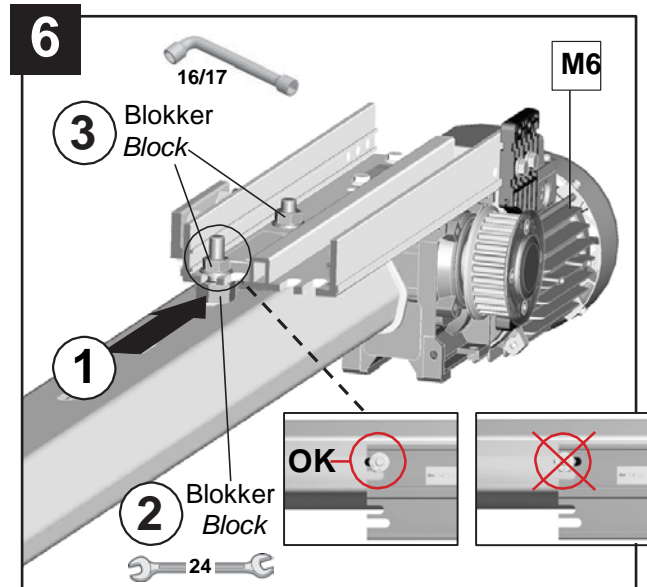
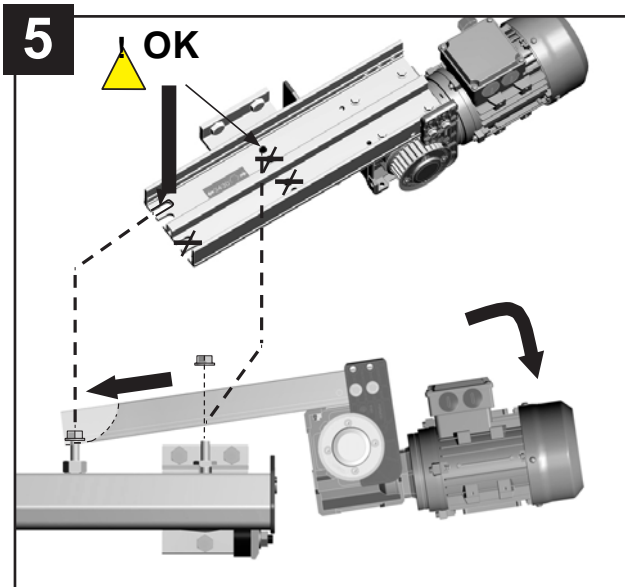
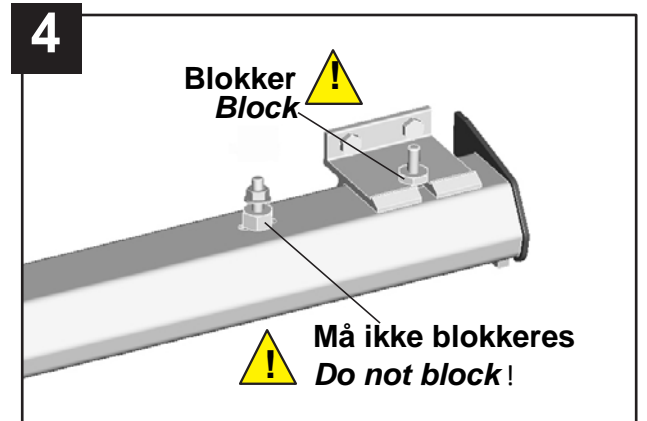
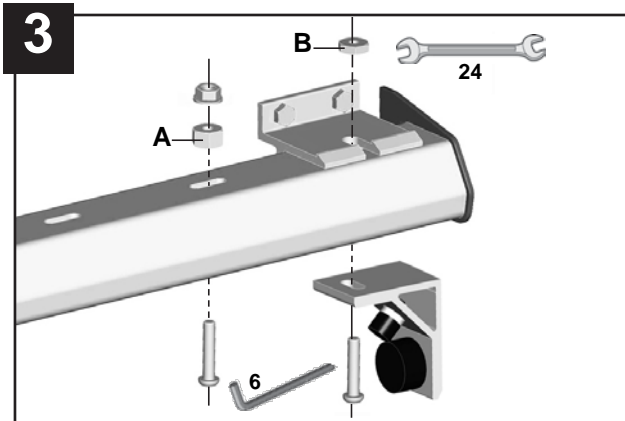
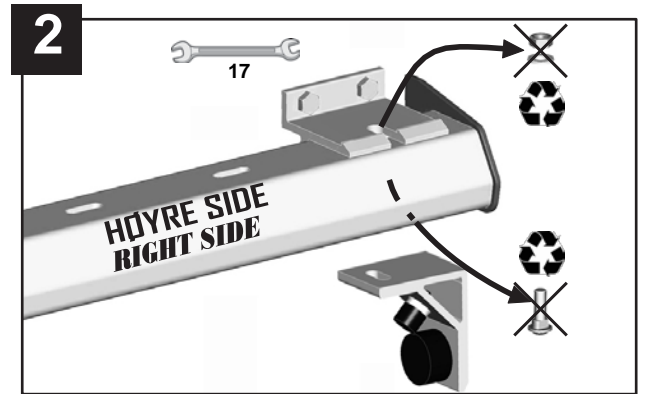
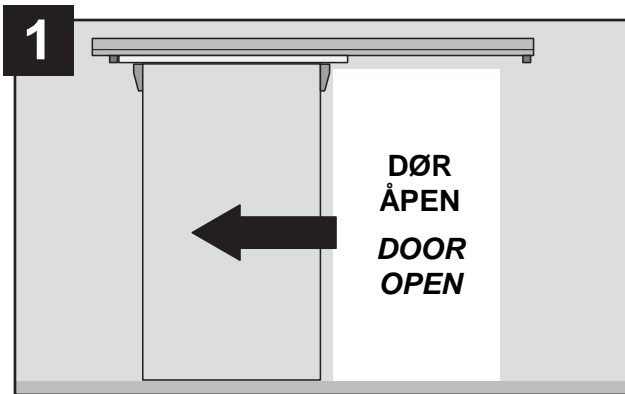
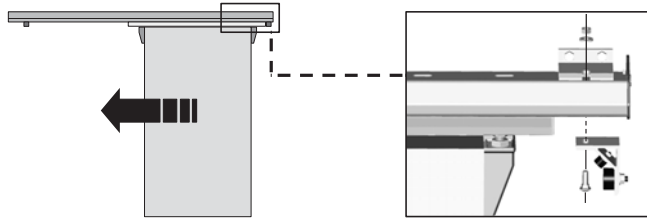
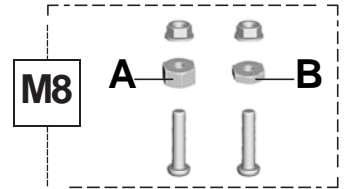

## 90° montering av motoren på høyre side / 90° right side motor mounting

Avhengig av installasjonen av systemet er det kanskje ikke nok plass på enden av høyre skinne for å montere motoren i dens standard konfigurasjon.

Da kan motoren monteres i 90° vinkel slik at den tar mindre plass.

*Depending on the system installation, the space available in the right end rail can be short for mounting the motor in its standard configuration. In that event it's possible to mount the motor in 90° direction.*

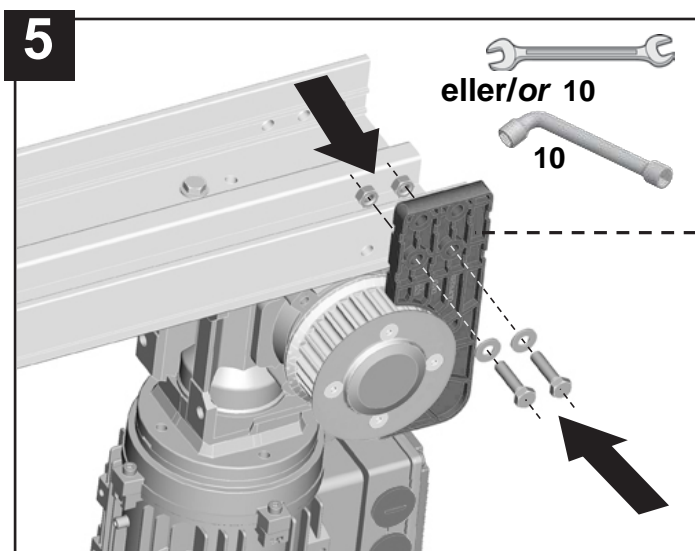
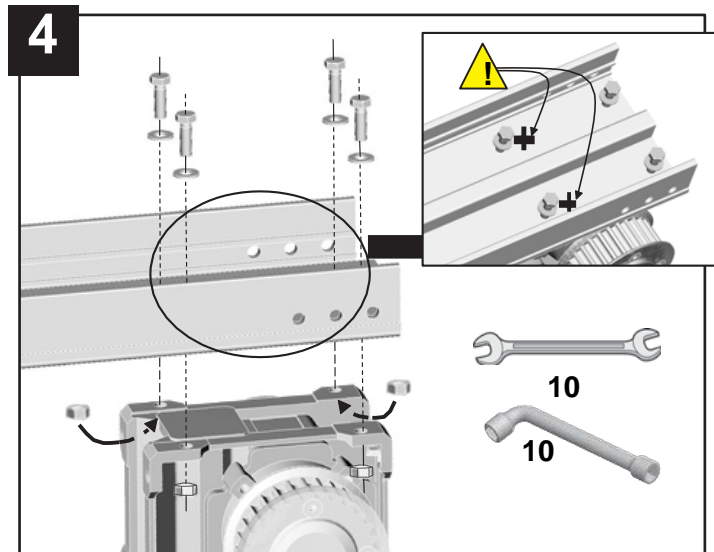
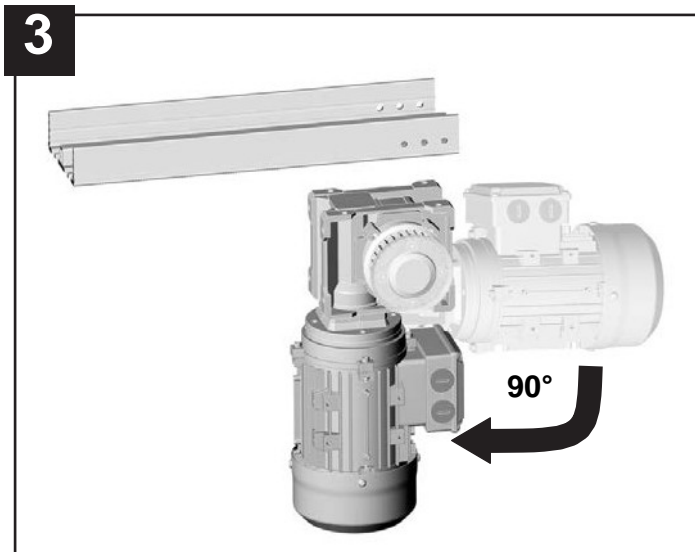
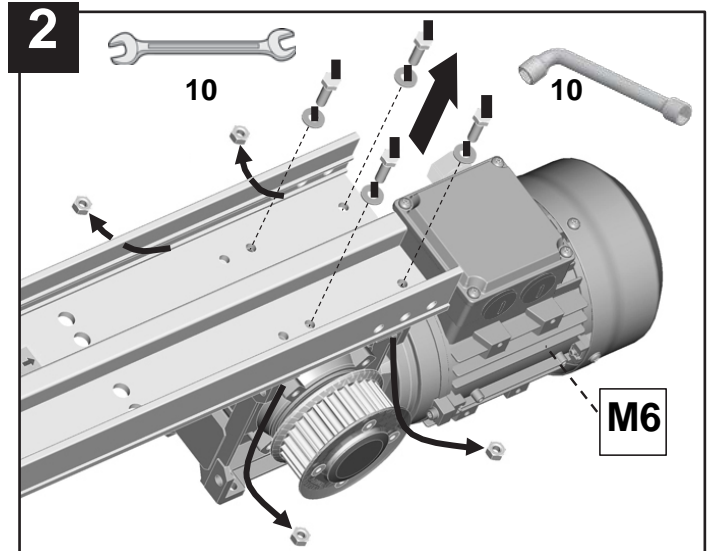
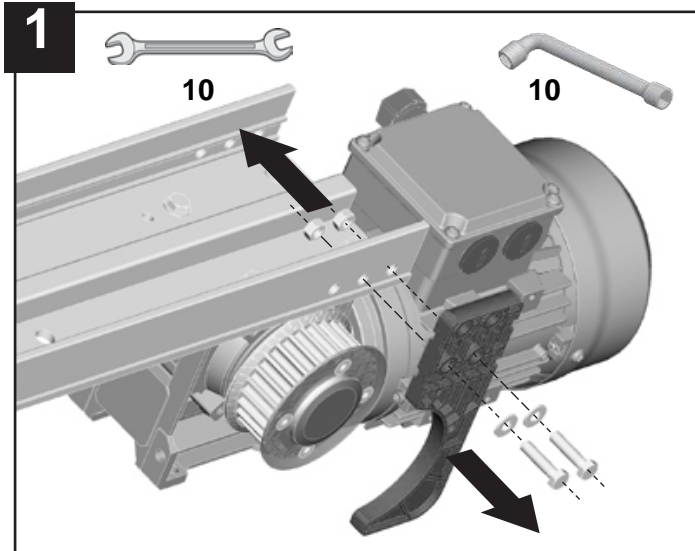

▪ **Omforming av motoren for montering på venstre side**  
*Transformation of the motor for left side mounting*

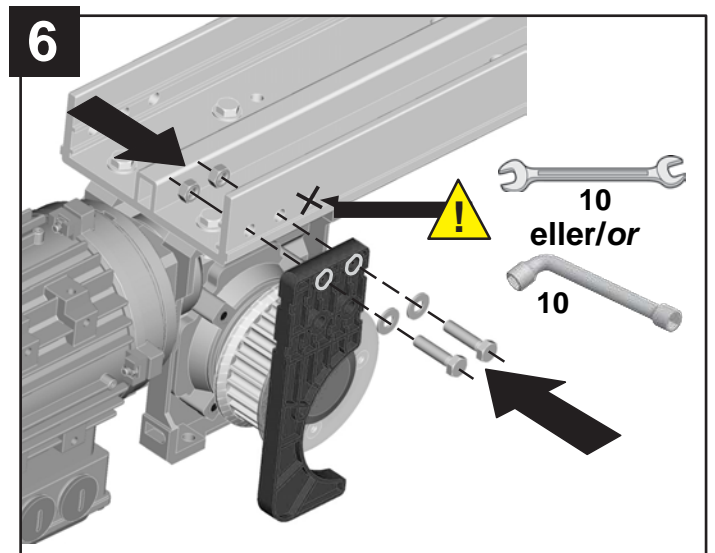
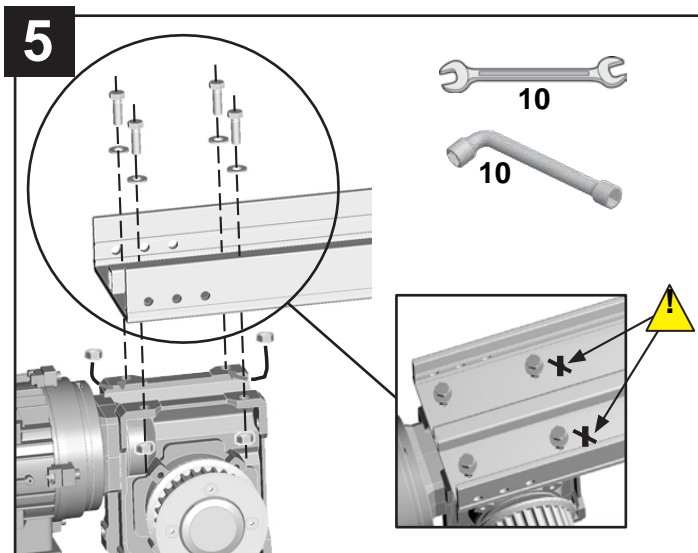
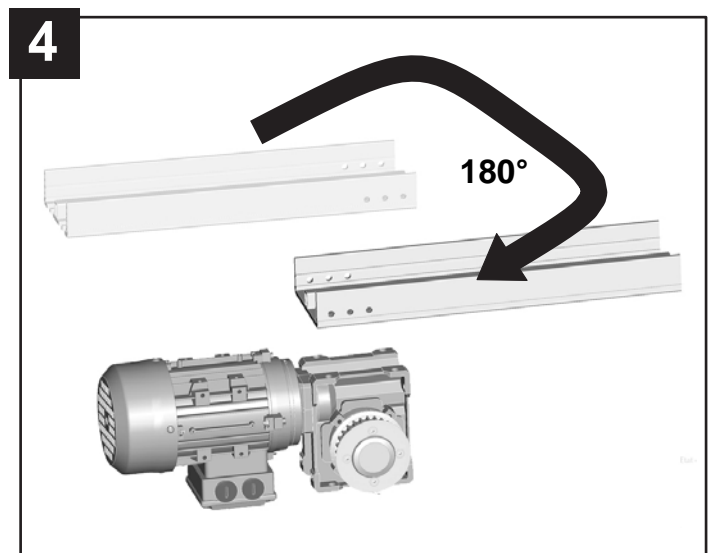
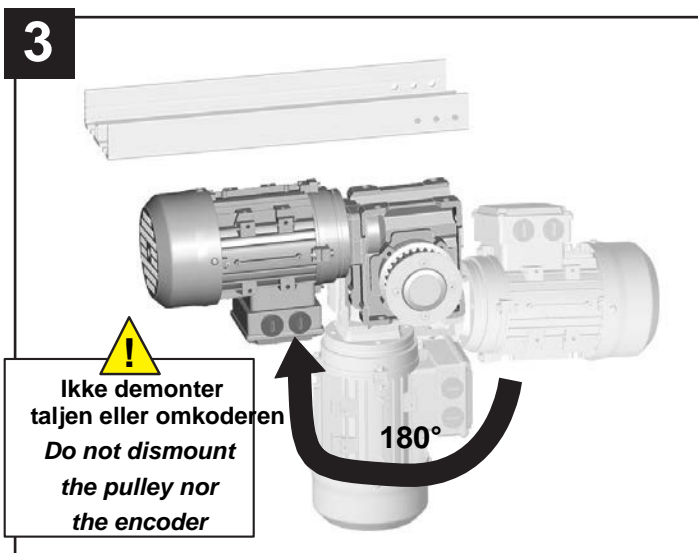
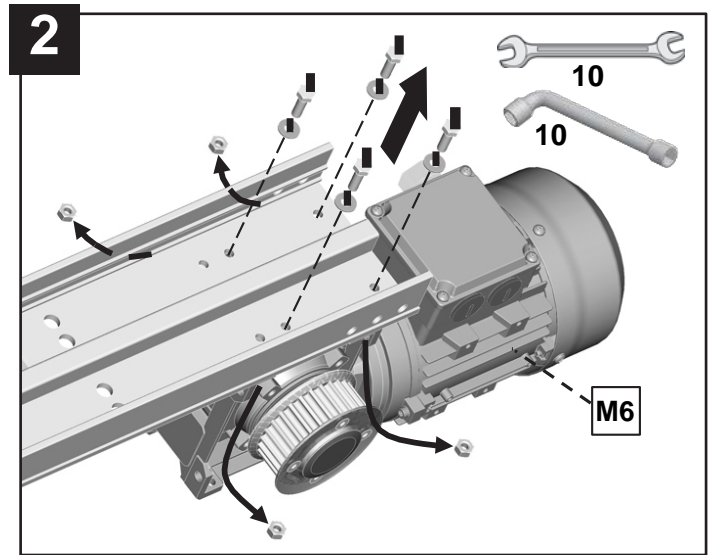
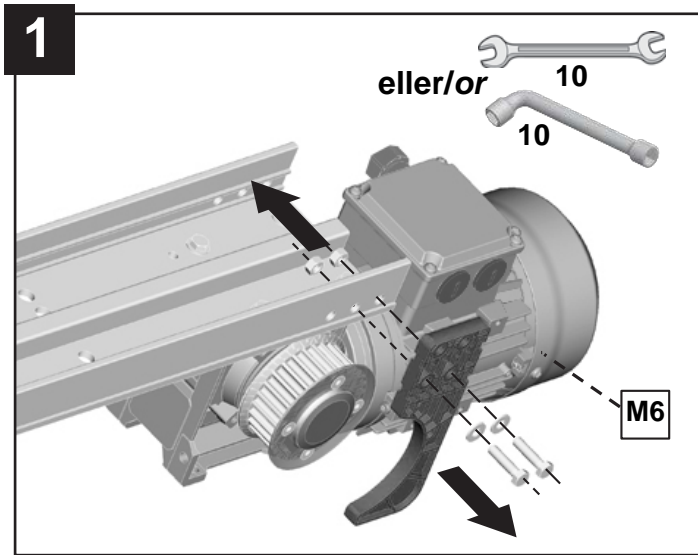

**90° montering av motoren på venstre side / 90° left side motor mounting**

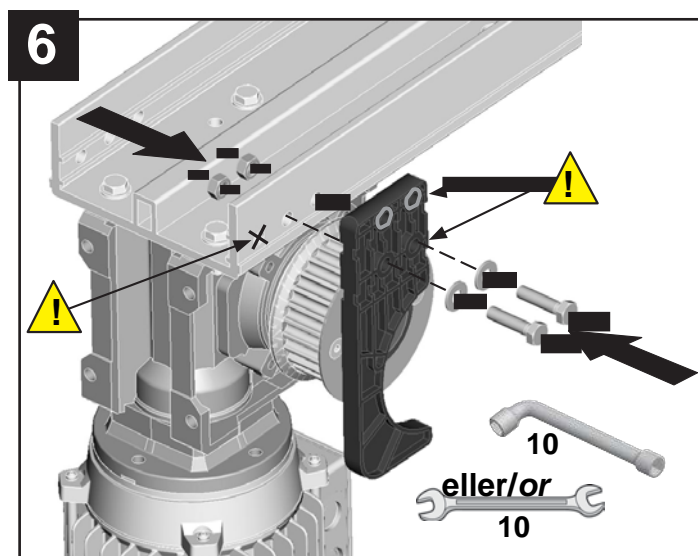
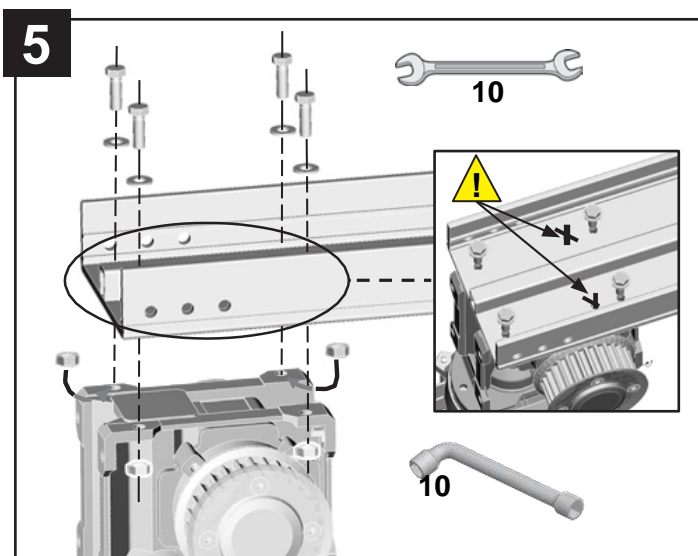
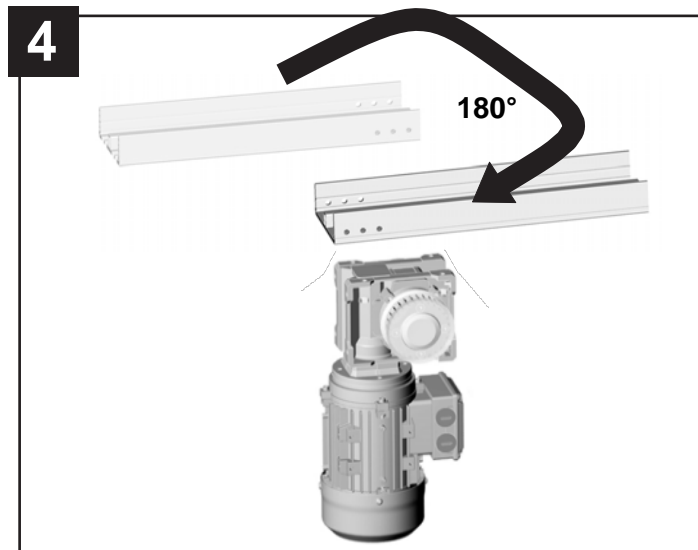
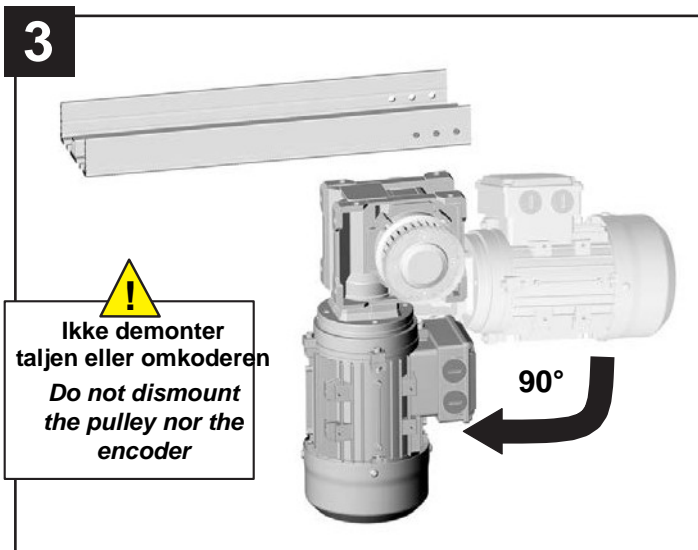
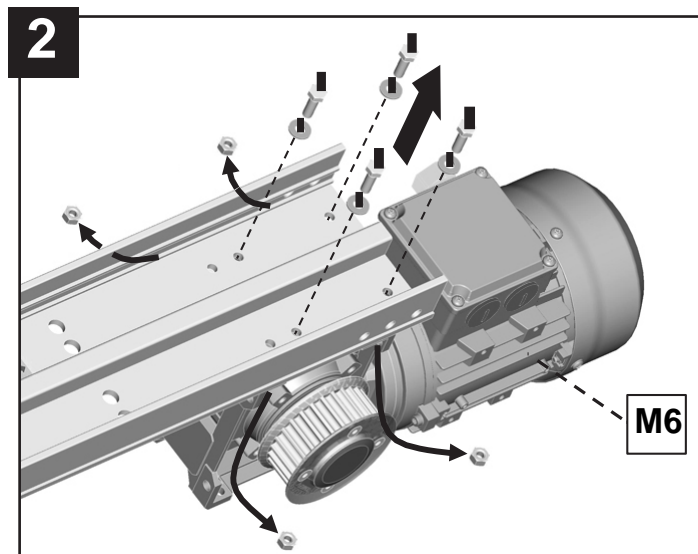
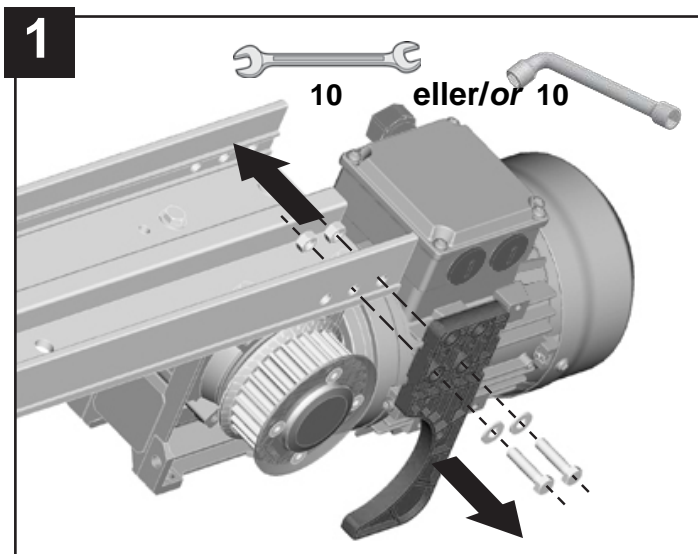

## 5.4 DRIVREM / BELT

### ▀ Kobling drivrem/dør - Link belt/door

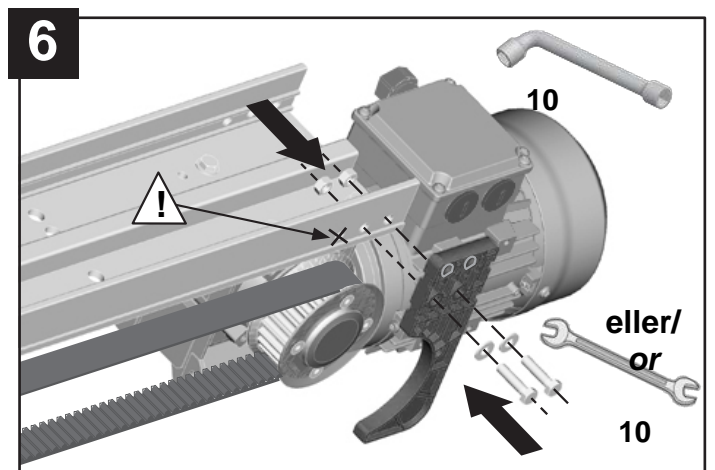
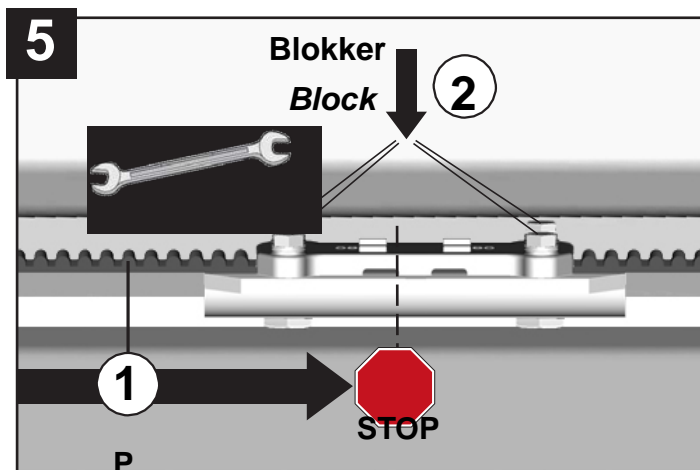
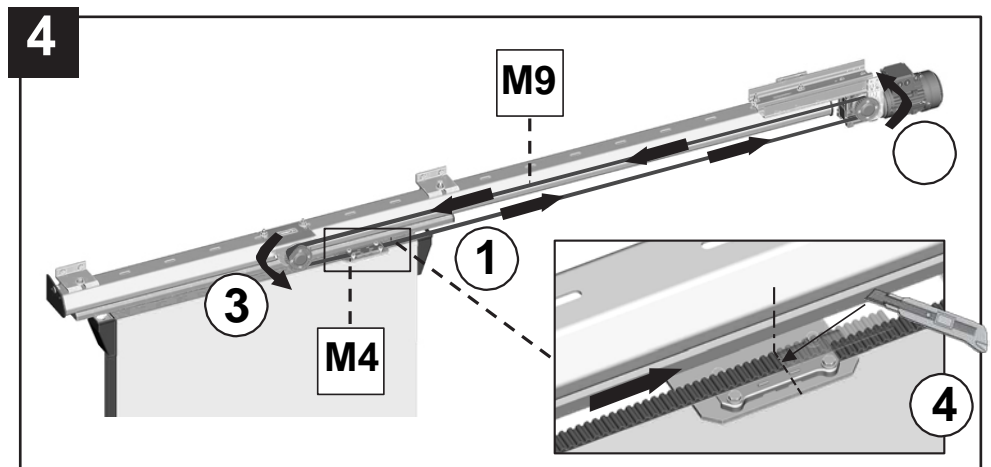
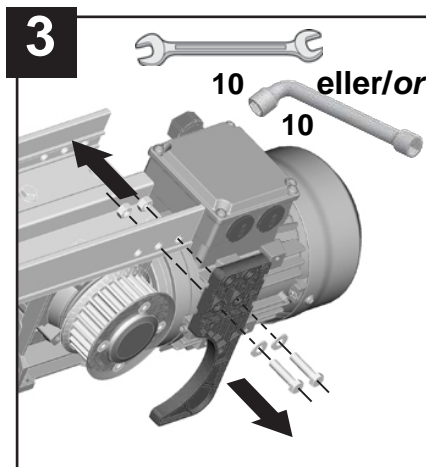
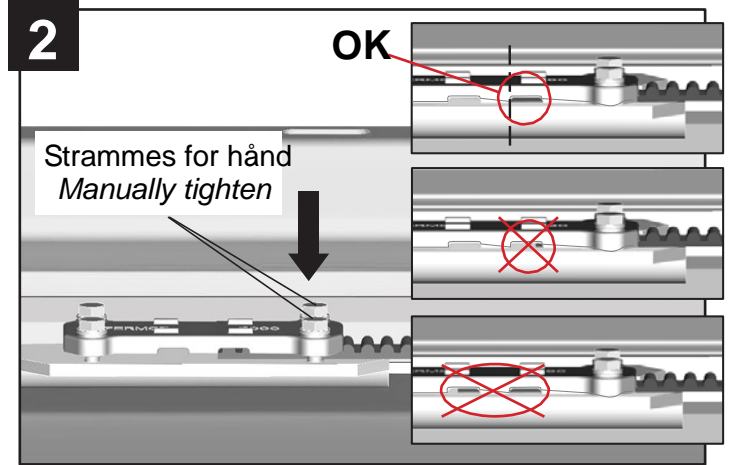
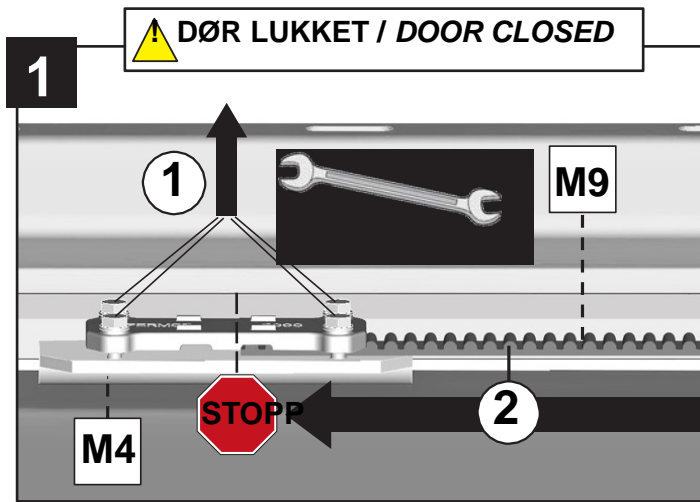

▪ **Spenne drivremmen / Tighten the belt**

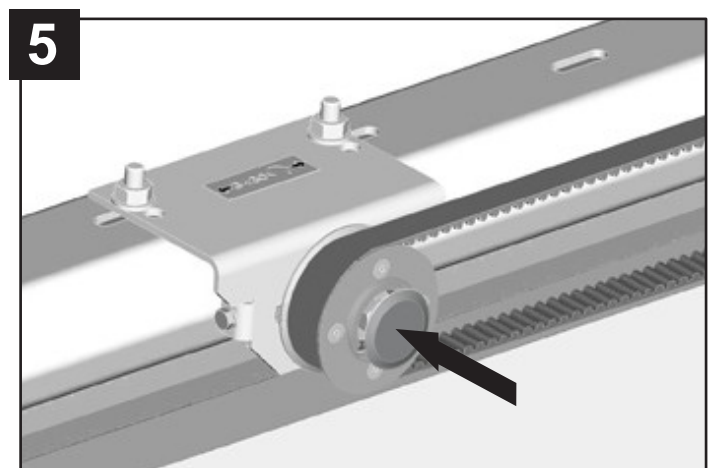
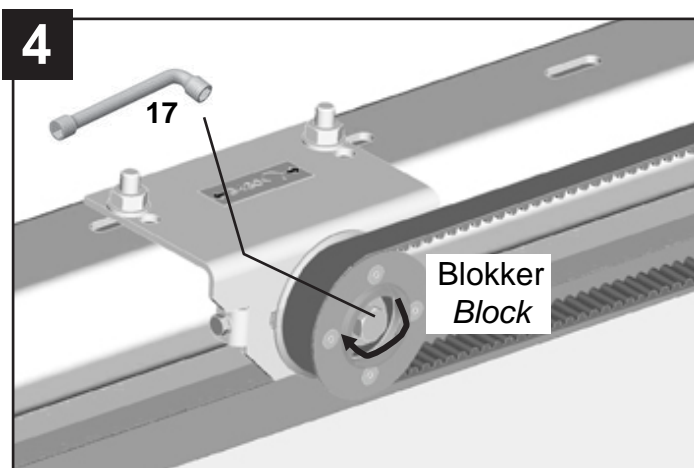
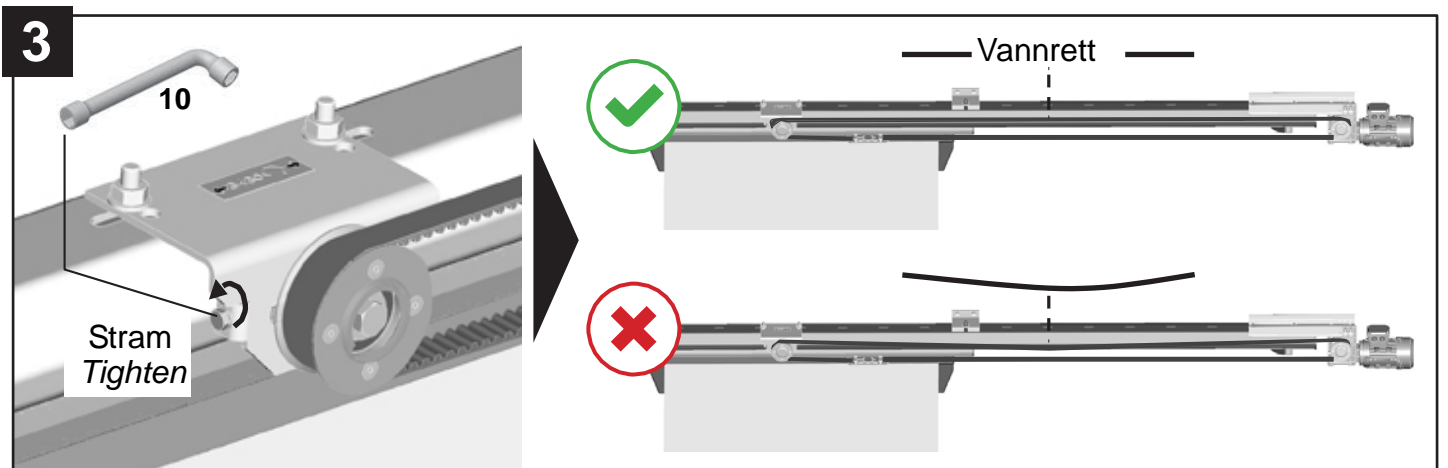
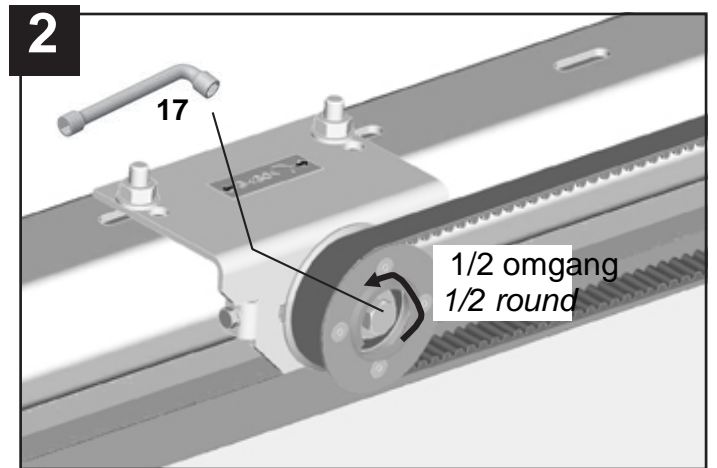
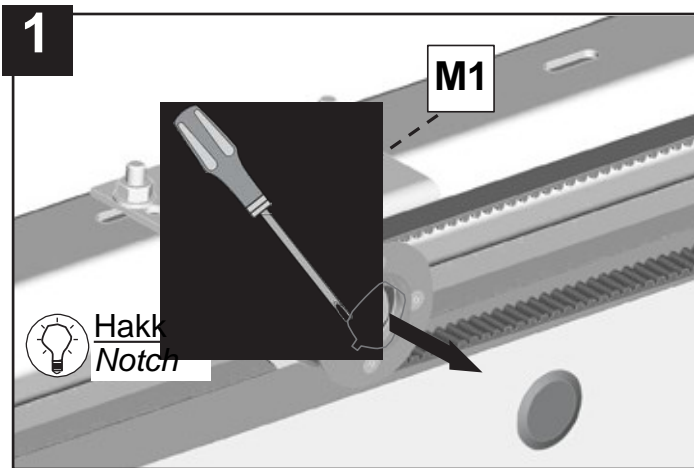

## 5.5 FESTING AV SIKKERHETSETIKETTER / SECURITY STICKERS FIXING

- i** Etikettene må plasseres så nær risikoområdene om mulig.  
*Stickers must be as nearest as possible to the risk.*

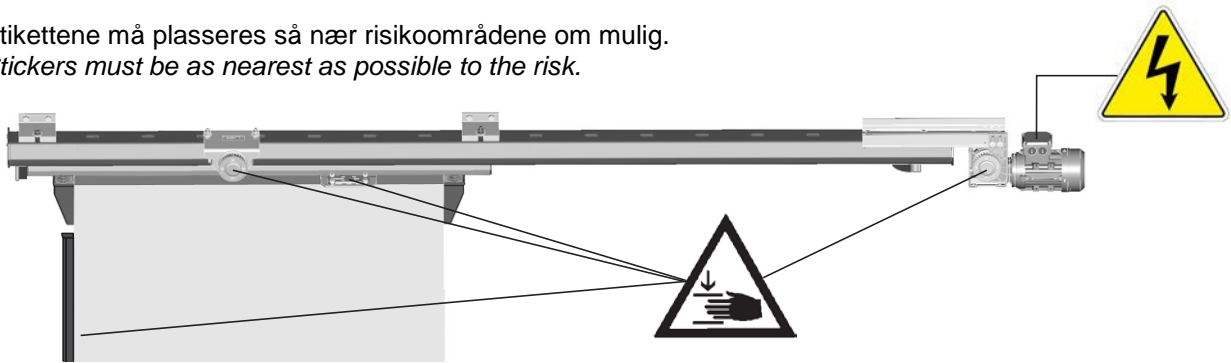

## 6 - BRUK / USING

### 6.1 NORMAL BRUK / NORMAL USING

Overhold spesifikasjonene i avsnitt 5 - Produktets karakteristikk. Bruk egnede kommandoer (knapp, brikke ...). Ved stillstand av de motoriserte dørene:

Brukeren kan åpne døren med det indre eller ytre håndtaket.

Forholdsregler:

**I nødstilfeller:** Trykk på den svarte knappen på kontrollboksen (motorstopp).

**Ved feil:** Slå av bryteren og bruk det egnede håndtaket.

*Respect § 5 specifications - Product Characteristics. Use the required commands (wall button, badge ...).*

In case of failure:

*The user can open the door with the internal or external handle.*

Safety measures:

**In case of emergency:** push on the black button of the wall command box (stop the motor).

**In case of failure:** put the switch off and use the required handle.

### 6.2 Risikoer som følge av handlinger utført av andre personer enn brukeren

**Risks following intentional acts of persons other than the user**



- . Fingrene klemmes mellom drivremmen og taljene (remstrammer eller motor)
- . Fingrene klemmes mellom dørens drivenhet og skinnens overside
- . Hånd mellom vognen og enden ved slutten av dørens åpning eller lukking
- . Hånd på rullene mens døren beveger seg

- . *Crushing of fingers placed between the belt and the pulleys (belt adjuster and motor)*
- . *Crushing of fingers placed between the door drive and the above of the rail*
- . *Handle between trolley and butt during the end of door opening or closing*
- . *Handle on the way of the rollers, when the door moves.*



- . Risiko for elektrisk støt
- . Ikke sprut vann
- . Ikke sprut støv eller materialbiter
- . Ikke la fremmedlegemer trenge inn i den elektriske kontrollboksen

- . *Danger: risk of electric shock*
- . *Do not spray with water*
- . *Do not spray dust or shavings*
- . *Do not introduce anything into command box*

## 6.3 IDENTIFIKASJONSETIKETTER / IDENTIFICATION STICKERS



**Motorbrakett**  
**Motor bracket**



**Drivenhet til dør**  
**Door driving assembly**



**Remstrammer**  
**Belt adjuster**

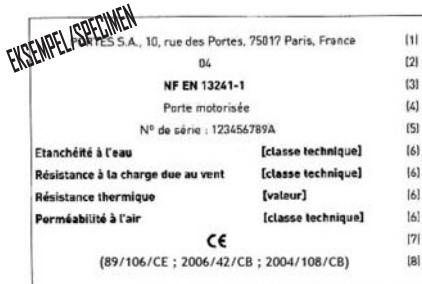

(1) Nom au marqueur d'identification et adresse enregistrée du producteur  
(2) Les deux derniers chiffres de l'année au cours de laquelle le marquage a été apposé  
(3) Numéro de la norme européenne de produit  
(4) Description du produit et utilisation prévue  
(5) Numéro d'identification  
(6) Informations sur les caractéristiques essentielles du produit  
(7) Symbole "CE" indiqué dans la Directive 93/68/CEE  
(8) Référence de la directive Produit de Construction, de la directive Machines et de la directive Compatibilité Electromagnétique

**Modell av CE-merkingsetikett (kun for kit 5010 CE) EC sticker example (only for kit 5010 CE)**

N°		2 1927	
AC	MOT	TRI	TYPE
	0,37		1500
	230 / 400	V	50 / 60 Hz
	1,4 / 0,8	A	IP 55
			RPM B
			Cos φ 0,67
			CL F S 1
FERMOD			

**Motorskilt**  
**Motor identification**

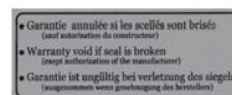

**Garantivilkår**  
**Warranty conditions**



Etikettene er kun til informasjon, de kan være gjenstand for endringer

Stickers data only for information - Subject to modifications

## 6.4 RENGJØRING / CLEANING

**Motorens beskyttelsesgrad: IP55 - Ikke spyl girmotoren**

**Kontrollboksens beskyttelsesgrad: IP65**

Egnet deksel beskytter mot spyling.

Det må ikke benyttes høytrykksspyling for å rengjøre dørens elektriske utstyr:

bryter, trykknapper, kontrollenhet, girmotor, loddrett optisk sikkerhet, vannrett optisk sikkerhet.

Materialene kan rengjøres med rengjøringsprodukter som er kompatible med materialene i det leverte produktet.

Konsentrasjonsgraden finner du i bruksanvisningene til rengjøringsproduktene som brukes.

**Materialer:**

- Dørens drivenhet / Remstrammer: galvanisert stål
- Motorbrakett: aluminium

**Water tightness class of the motor: IP55 - Do not splash.**

**Water tightness class of the command box: IP65**

Protection against water splashes with the suited cover.

Cleaning the door must exclude the use of a water jet on electrical appliances: push buttons, control unit, reduction gear, horizontal optical safety.

The equipment should be cleaned using cleaning agents that are compatible with the materials of the supplied product. For the dilution percentages, refer to the instructions of the cleaning agents to be used.

**Materials:**

- Door driving assembly / Belt adjuster: zinc steel
- Motor bracket: aluminium



## 7 - VEDLIKEHOLD / MAINTENANCE

Sluttbrukeren må foreta, eller få foretatt, periodiske årlige og halvårslige kontroller, og føre et vedlikeholdsregister. Vedlikeholdet må foretas av en kvalifisert person.

Sjekk spenningen og strømstyrken til ledningen som tilfører strøm til den elektroniske enheten (**merk:** )  
Når en komponent byttes ut, velg den riktige komponenten fra produsentens ettersalgsservice, og følg instruksjonene i de ulike kapitlene i denne instruksjonshåndboken.

*The final user must carry out periodical yearly or twice-yearly checks, or have them carried out, with keeping of a maintenance register.*

*Maintenance must be carried out by qualified staff.*

*Check the voltage and amperage of the line feeding the electronic unit. ()*

*When replacing a component, choose the right component from the manufacturer's after-sales service, and respect the instructions of the different sections in this instruction manual.*

### Kontroller de viktigste slitedelene / Watch the main consumable parts :

SLITEDELER Consumable parts	Intervaller for vedlikehold Regularity of maintenance	Kriterier for kassering Criteria for scrapping
Rem Belt	20 000 sykluser eller årlig 20 000 cycles or yearly	Begynnende slitasje Beginning of tear
Remstrammer Belt adjuster	50 000 sykluser	Slark på akselen til tannhjul Play on the toothed wheel shaft
Motor / Motor		

## 8 - KASSERING / SCRAPPING

Ta hensyn til alle nasjonale regler og forskrifter som omhandler behandling av avfall og emballasje. Det avtales at kjøperen som besitter dette utstyret, skal sørge for å finansiere og organisere avfallet som kommer fra dette utstyret.

Når kjøperen kaster avfallet, skal det beholdes dokumentasjon på at reglene har blitt fulgt. Når følgende deler kasseres, må de demonteres og kjøres bort til et gjenvinningsanlegg. Disse materialene avgir giftige gasser når de brenner:

*Take all the national regulation texts into consideration, which deal with scrap and packaging waste.*

*It is agreed that the buyer, keeping this equipment, shall ensure the financing and organization of scrapping the waste from this equipment.*

*The buyer when scrapping his waste, should keep proof of the full application of these regulation obligations. Scrapping the following items requires dismantling and disposal at a waste treatment center.*

*These materials give off harmful vapours during combustion:*

Del / Designation	Sammensetning / Composition
Displaybrakett Display bracket	ABS



**FERMOD**



75, rue de Richelieu – 75002 PARIS – FRANCE  
tlf.: + 33 (0)1 42 96 94 06 - faks: + 33 (0)1 42 86 84 51

<http://www.fermod.com> – e-post: [contact@fermod.com](mailto:contact@fermod.com)

Hovedkontor: Senlis (Oise) – Aksjeselskap med kapital på 1 004 400 euro  
RCS Compiègne B 301 468 211 – Org. nr. 301 468 211 00018 - APE 2572Z

DISTRIBUTØR  
DISTRIBUTOR